

INTERNATIONAL JOURNAL OF
ENGINEERING (IJE)

ISSN : 1985-2312

Volume 8 • Issue 4 • July 2014
Publication Frequency: 6 Issues / Year



CSC PUBLISHERS
<http://www.cscjournals.org>

Copyrights © 2014 Computer Science Journals. All rights reserved.

INTERNATIONAL JOURNAL OF ENGINEERING (IJE)

VOLUME 8, ISSUE 4, 2014

**EDITED BY
DR. NABEEL TAHIR**

ISSN (Online): 1985-2312

International Journal of Engineering is published both in traditional paper form and in Internet.

This journal is published at the website <http://www.cscjournals.org>, maintained by Computer Science Journals (CSC Journals), Malaysia.

IJE Journal is a part of CSC Publishers

Computer Science Journals

<http://www.cscjournals.org>

INTERNATIONAL JOURNAL OF ENGINEERING (IJE)

Book: Volume 8, Issue 4, July 2014

Publishing Date: 01-07-2014

ISSN (Online): 1985-2312

This work is subjected to copyright. All rights are reserved whether the whole or part of the material is concerned, specifically the rights of translation, reprinting, re-use of illustrations, recitation, broadcasting, reproduction on microfilms or in any other way, and storage in data banks. Duplication of this publication of parts thereof is permitted only under the provision of the copyright law 1965, in its current version, and permission of use must always be obtained from CSC Publishers.

IJE Journal is a part of CSC Publishers

<http://www.cscjournals.org>

© IJE Journal

Published in Malaysia

Typesetting: Camera-ready by author, data conversion by CSC Publishing Services – CSC Journals, Malaysia

CSC Publishers, 2014

EDITORIAL PREFACE

This is the *Fourth* Issue of Volume *Eight* for International Journal of Engineering (IJE). The Journal is published bi-monthly, with papers being peer reviewed to high international standards. The International Journal of Engineering is not limited to a specific aspect of engineering but it is devoted to the publication of high quality papers on all division of engineering in general. IJE intends to disseminate knowledge in the various disciplines of the engineering field from theoretical, practical and analytical research to physical implications and theoretical or quantitative discussion intended for academic and industrial progress. In order to position IJE as one of the good journal on engineering sciences, a group of highly valuable scholars are serving on the editorial board. The International Editorial Board ensures that significant developments in engineering from around the world are reflected in the Journal. Some important topics covers by journal are nuclear engineering, mechanical engineering, computer engineering, electrical engineering, civil & structural engineering etc.

The initial efforts helped to shape the editorial policy and to sharpen the focus of the journal. Started with Volume 8, 2014, IJE appears with more focused issues. Besides normal publications, IJE intend to organized special issues on more focused topics. Each special issue will have a designated editor (editors) – either member of the editorial board or another recognized specialist in the respective field.

The coverage of the journal includes all new theoretical and experimental findings in the fields of engineering which enhance the knowledge of scientist, industrials, researchers and all those persons who are coupled with engineering field. IJE objective is to publish articles that are not only technically proficient but also contains information and ideas of fresh interest for International readership. IJE aims to handle submissions courteously and promptly. IJE objectives are to promote and extend the use of all methods in the principal disciplines of Engineering.

IJE editors understand that how much it is important for authors and researchers to have their work published with a minimum delay after submission of their papers. They also strongly believe that the direct communication between the editors and authors are important for the welfare, quality and wellbeing of the Journal and its readers. Therefore, all activities from paper submission to paper publication are controlled through electronic systems that include electronic submission, editorial panel and review system that ensures rapid decision with least delays in the publication processes.

To build its international reputation, we are disseminating the publication information through Google Books, Google Scholar, Directory of Open Access Journals (DOAJ), Open J Gate, ScientificCommons, Docstoc and many more. Our International Editors are working on establishing ISI listing and a good impact factor for IJE. We would like to remind you that the success of our journal depends directly on the number of quality articles submitted for review. Accordingly, we would like to request your participation by submitting quality manuscripts for review and encouraging your colleagues to submit quality manuscripts for review. One of the great benefits we can provide to our prospective authors is the mentoring nature of our review process. IJE provides authors with high quality, helpful reviews that are shaped to assist authors in improving their manuscripts.

Editorial Board Members

International Journal of Engineering (IJE)

EDITORIAL BOARD

ASSOCIATE EDITORS (AEiCs)

Professor. Ernest Baafi
University of Wollongong
Australia

Dr. Tarek M. Sobh
University of Bridgeport
United States of America

Dr. Cheng-Xian (Charlie) Lin
University of Tennessee
United States of America

Assistant Professor Aleksandar Vujovic
Univeristy of Montenegro

Assistant Professor Jelena Jovanovic
University of Montenegro
Serbia and Montenegro

EDITORIAL BOARD MEMBERS (EBMs)

Professor. Jing Zhang
University of Alaska Fairbanks
United States of America

Dr. Tao Chen
Nanyang Technological University
Singapore

Dr. Oscar Hui
University of Hong Kong
Hong Kong

Professor. Sasikumaran Sreedharan
King Khalid University
Saudi Arabia

Assistant Professor. Javad Nematian
University of Tabriz Iran

Dr. Bonny Banerjee
Senior Scientist at Audigence
United States of America

Associate Professor. Khalifa Saif Al-Jabri
Sultan Qaboos University
Oman

Dr. Alireza Bahadori
Curtin University
Australia

Dr Guoxiang Liu
University of North Dakota
United States of America

Dr Rosli
Universiti Tun Hussein Onn
Malaysia

Professor Dr. Pukhraj Vaya
Amrita Vishwa Vidyapeetham
India

Associate Professor Aidy Ali
Universiti Putra Malaysia
Malaysia

Professor Dr Mazlina Esa
Universiti Teknologi Malaysia
Malaysia

Dr Xing-Gang Yan
University of Kent
United Kingdom

Associate Professor Mohd Amri Lajis
Universiti Tun Hussein Onn Malaysia
Malaysia

Associate Professor Tarek Abdel-Salam
East Carolina University
United States of America

Associate Professor Miladin Stefanovic
University of Kragujevac
Serbia and Montenegro

Associate Professor Hong-Hu Zhu
Nanjing University
China

Dr Mohamed Rahayem
Örebro University
Sweden

Dr Wanquan Liu
Curtin University
Australia

Professor Zdravko Krivokapic
University of Montenegro
Serbia and Montenegro

Professor Qingling Zhang
Northeastern University
China

TABLE OF CONTENTS

Volume 8, Issue 4, July 2014

Pages

- 38 – 48 Wind-Driven SEIG Systems: A Comparison Study
Mohamed Zaid Abdulkarim, Abdulhakim Saeed Noman

Wind-Driven SEIG Systems: A Comparison Study

Mohamed Zaid A. Karim

*Faculty of Engineering/ Department of Electrical Engineering
University of Aden
Aden/ Yemen*

mdzakarim6@yahoo.com

A. Hakim Saeed Noman

*Faculty of Engineering/ Department of Electrical Engineering
University of Aden
Aden/ Yemen*

ahakim201@yahoo.com

Abstract

Wind energy is one of the fastest growing renewable energies in the world. This is because it has a much lower environmental impact than conventional energy. In addition, it is one of the lowest-priced renewable energy technologies.

Due to wind speed variation, induction generators are the best choice for such applications. However, they have poor voltage and frequency regulation against wind speed or load variations.

For its operation, the induction generator needs a reasonable amount of reactive power. In stand-alone applications, the reactive power could be supplied to the induction generator by a bank of capacitors as implemented here.

In this paper, simulation of wind turbine driven self excited induction generator (SEIG) has been carried out. Three methods of voltage and frequency regulation have been presented, simulated and analyzed.

The aim of this paper is to compare the three methods from many aspects highlighting the advantages and disadvantages of each one.

Keywords: Wind Energy, Induction Generators, Self Excitation, Voltage Regulation, Frequency Regulation.

1. INTRODUCTION

Renewable energy technologies are clean sources of energy that have a much lower environmental impact than conventional energy technologies such as coal, oil, nuclear and natural gas. In addition, renewable energy resources will never run out while conventional sources of energy are finite and will someday be used up.

Wind turbines are the main components of wind farms. They are usually mounted on towers to capture the most kinetic energy. Turbines catch the wind's energy with their blades. These blades, usually three, are mounted on a shaft to form a rotor. Wind turbines could be of vertical axis [1] or horizontal axis wind turbines.

Use of induction generators is becoming very popular for utilizing renewable energy sources and converting it into electrical energy [2]. Self-excited induction generators have been widely used during the last decades in wind energy conversion systems in remote isolated areas. Despite the well known favorable features of induction generators, they, however, have unsatisfactory voltage and frequency regulation with variation in load and speed [3].

In standalone applications, bank of capacitors are required to provide the reactive power for the induction generator. The voltage build-up is initiated either by the generator residual flux or by the pre-charged excitation capacitors. The steady state voltage and frequency depends

on the value of the excitation capacitors, the load, the magnetization characteristics and the prime mover speed. The electrical load is continuously changing by nature as well as the prim-mover speed. Thus, it is not an easy task to regulate the voltage and frequency of self excited induction generators [4, 5].

Many researchers have determined the minimum capacitor for self-excited induction generator. A simple and accurate method of calculating the minimum values of the excitation capacitors is proposed in [6, 7].

Reactive power consumption and poor voltage and frequency regulation are the main drawbacks of SEIGs. Many researches proposed many methods of voltage and frequency regulations [5, 8-13].

In the present work, three systems of wind turbines-driven self excited induction generator have been studied, simulated and analyzed using Matlab software. The three systems are compared and their merits and demerits are highlighted.

2. SELF EXCITATION AND MATHEMATICAL MODEL OF THE SEIG

As mentioned above, the main drawback of induction generator in wind energy conversion system applications is its need for a reactive power to build up the terminal voltage and to generate electric power. Using capacitors across generator terminals can provide this reactive power.

For the generator under consideration, the minimum values of the 3- ϕ , Y-connected, excitation capacitors values are found to be 169 μ F each. These values are selected so that the SEIG produces the rated voltage at full-load condition.

If the value of the capacitor is so high, the corresponding excitation current may, by far, exceed the rated current of the machine. This may damage the machine [7]. Thus, the maximum value of the capacitor is taken corresponding to the rated current of the induction generator.

These capacitors are included in the generator dynamic equation. The d-q model of the self-excited induction generator, in the stationary stator reference frame, is given as [14]:

$$\begin{bmatrix} 0 \\ 0 \\ 0 \\ 0 \end{bmatrix} = \begin{bmatrix} R_s + pL_s + \frac{1}{pC} & 0 & pL_m & 0 \\ 0 & R_s + pL_s + \frac{1}{pC} & 0 & pL_m \\ pL_m & -\omega_r L_m & R_r + pL_r & -\omega_r L_r \\ \omega_r L_m & pL_m & \omega_r L_r & R_r + pL_r \end{bmatrix} \begin{bmatrix} i_{qs} \\ i_{ds} \\ i_{qr} \\ i_{dr} \end{bmatrix} + \begin{bmatrix} V_{cq0} \\ V_{cd0} \\ -K_{qr} \\ K_{dr} \end{bmatrix}$$

where,

R_s and R_r are the stator and rotor resistances respectively

$L_s = L_{ls} + L_m$ and $L_r = L_{lr} + L_m$

L_{ls} and L_{lr} are the stator and rotor leakage inductances respectively

L_m is the magnetizing inductance

C is the excitation capacitance

p is the differential operator (d/dt)

ω_r is the equivalent electrical rotor speed in radians per second

i_{qs} , i_{ds} , i_{qr} and i_{dr} are stator and rotor quadrature and direct axis current components

V_{cq0} and V_{cd0} are the initial capacitors voltages along the q-axis and d-axis respectively

$K_{qr} = \omega_r \lambda_{dr0}$ and $K_{dr} = \omega_r \lambda_{qr0}$, are constants which represent the initial induced voltages along the q-axis and d-axis, respectively. These constants are due to the residual magnetic flux in the core

λ_{qr0} and λ_{dr0} are the residual rotor flux linkages along the q-axis and d-axis, respectively

3. SIMULATION OF THE WIND-DRIVEN SEIG

The self excited induction generator can produce rated voltage and frequency if the value of the reactive power required by the generator is properly adjusted. However, this voltage fluctuates with wind speed and load variation.

In this paper, three systems are considered to regulate the voltage and frequency. They are designated, here, as System 1, System 2 and System 3.

Specifications of the test turbine and induction machine used in this simulation are [15]:

- Turbine: 3600 W, diameter is 5.5 m, base wind speed is 8 m/s, air density is 1.23 kg/m³ and power coefficient is 0.48
- Induction machine: 3- ϕ , 3 kVA, 380 V, 50 Hz, 4-Poles, Squirrel cage, Y-connected. $R_s = 2.03$ Ohm, $R'_r = 2.3$ Ohm, $X_{ls} = 4.15$ Ohm, $X'_{lr} = 4.2$ Ohm, $X_m = 79$ Ohm
- Load: 2050 W, 800 VAR

With no control, the schematic diagram for SEIG, as constructed in Matlab software, is presented in Figure 1. It consists of three phase, star connected squirrel cage induction machine working as self-excited induction generator and suitable values of excitation capacitances across its stator terminals.

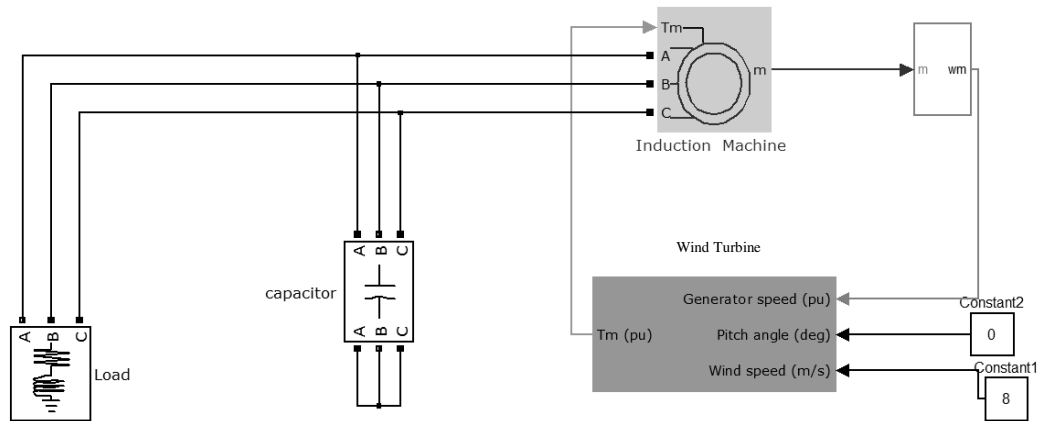

FIGURE 1: Self excited induction generator with wind turbine.

With 8 m/s (base speed) and 0° pitch angle, the simulated output voltage and its frequency so obtained are shown in Figure 2 (a) and (b) respectively at full-load.

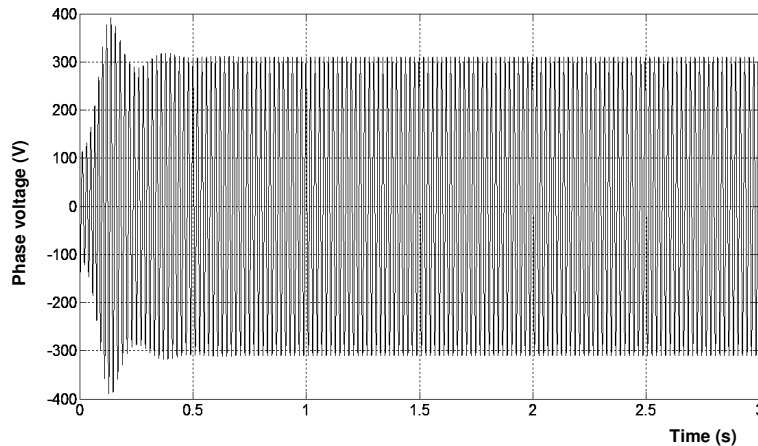

FIGURE 2 (a): Variation of Output Voltage.

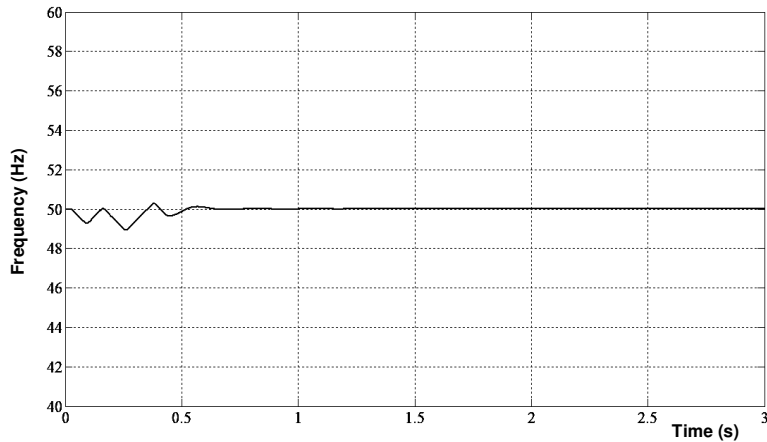

FIGURE 2 (b): Variation of Output Frequency.

To illustrate the effect of wind speed variation, the speed is assumed variable in the manner shown in Figure 3. The variation is made every 3 seconds. The corresponding output voltage is shown in Figure 4. The load is kept fixed at its full-load level. As seen, the generator voltage varies with the wind speed. The frequency, however, remains almost unchanged [16].

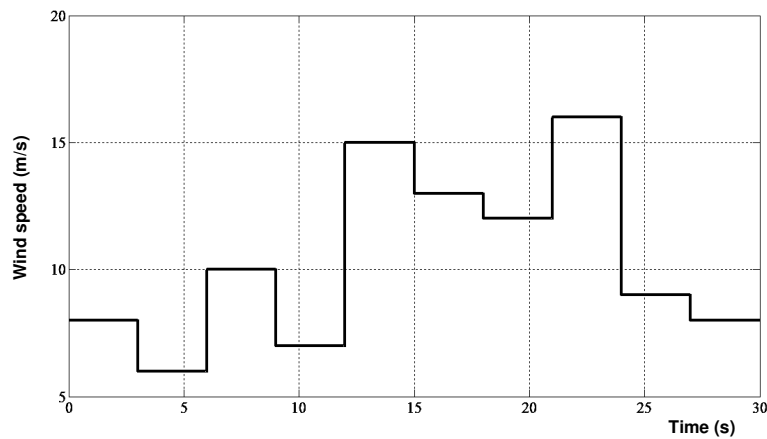

FIGURE 3: Variation of Wind Speed.

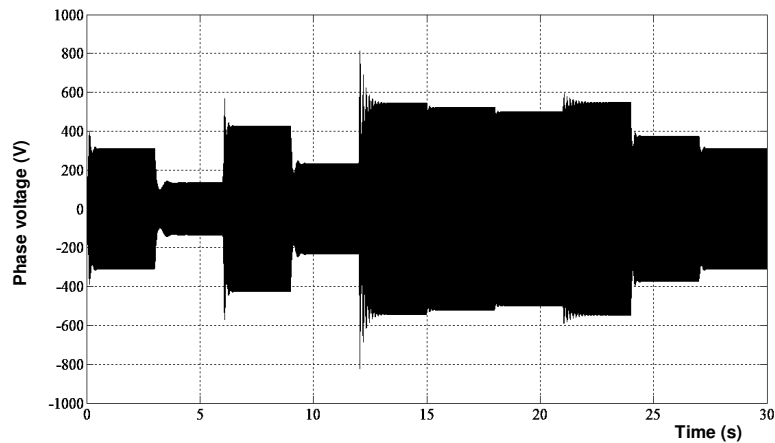

FIGURE 4: Variation of Output Phase Voltage.

The generated voltage and its frequency are also affected due to load variation. By varying the load in steps, the corresponding output voltages and frequencies are tabulated in Table 1.

Active load (watt)	Reactive load (VAR)	RMS Phase voltage (volt)	Frequency (Hz)
2050	800	220	50
1800	700	230.5	49.44
1600	600	241	48.85
1400	500	251.73	48.27
1200	400	264.45	47.7
1000	300	282.842	47.15
800	200	293.45	46.6
600	100	312.5	46

TABLE 1: Effect of load variation on output voltage and frequency.

As expected, the above table reveals that the output voltage increases as the load is decreased. It is seen that the frequency decreases as the load is decreased. However, the change in frequency is small as compared to the voltage change.

4. VOLTAGE REGULATION AGAINST WIND SPEED VARIATION

Variation of wind speed could be below or above the base wind speed. At low wind speed, the output voltage decreases. According to the results given in Table 1, the load has to be appropriately disconnected to bring back the output voltage to its rated value.

At higher values of wind speed, the output voltage increases. In such cases, pitch angle control is used to control the generator output voltage. As wind speed increases, pitch angle has to be suitably increased

5. VOLTAGE AND FREQUENCY REGULATION AGAINST LOAD VARIATION

For voltage and frequency regulation against load variation, three systems are considered in the present work.

❖ System 1:

The system is presented in Figure 5. It consists of SEIG connected to the load through a dc-link PWM voltage source inverter (VSI).

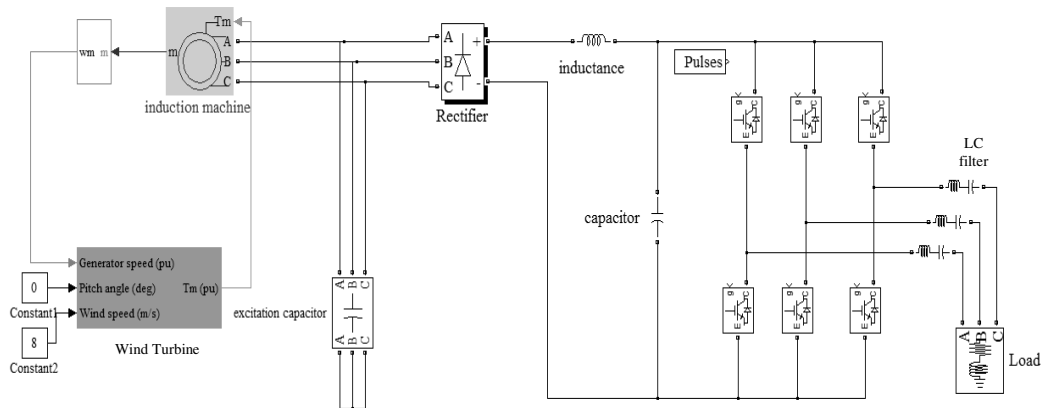

FIGURE 5: System 1.

In System 1, the generator is supplied with constant reactive power. The output voltage can be controlled by adjusting the inverter modulation index (MI). The output frequency is fixed by the frequency of the reference voltage of the inverter control circuit. Thus, the voltage and frequency at the load side can be maintained at the required rated values i.e. 220 V (rms) and 50 Hz.

For the system under consideration, the frequency is set in the control circuit as 50 Hz and the modulation index is set as 0.7 at full-load condition. With base wind speed (8 m/s), the output voltage thus obtained is the rated value as shown in Figure 6.

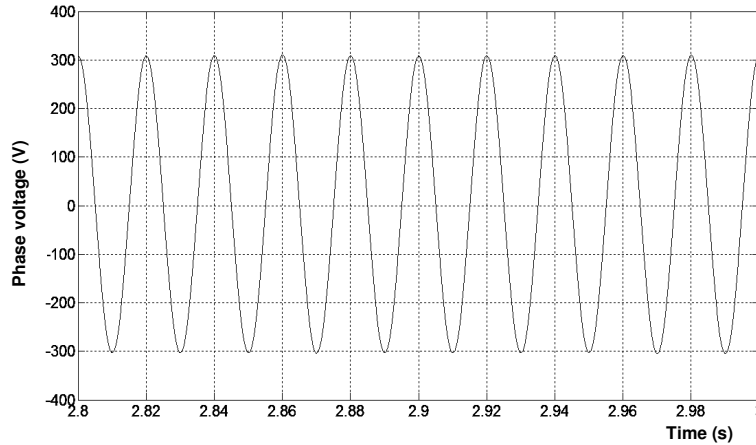

FIGURE 6: Variation of output phase voltage (System 1).

For other settings of load level, the (MI) has to be adjusted to obtain rated load voltage. The frequency remains fixed at 50 Hz. For other load levels, the modulation index is worked out and presented in Table 2.

Active load (watt)	Reactive load (VAR)	Modulation index (MI)
1600	600	0.443
1400	500	0.425
1200	400	0.415
1000	300	0.405
800	200	0.403
600	100	0.400

TABLE 2: Modulation index at different load levels (System 1).

As the load is reduced, the generated voltage gets increased to a value which may, by far, exceed the rated value. This is because the reactive power supplied by the capacitor is fixed corresponding to full-load condition and not controlled by the inverter. The load voltage can be maintained constant through modulation index control. However, increase of generator voltage beyond the rated value is not allowed. Thus, this type of control should be accompanied with pitch angle control to prevent the generator voltage from exceeding the rated value.

The disadvantage of this system is that, at reduced wind speed, the generated voltage decreases. Since the reactive power is fixed, load shedding is implemented to bring the generator voltage back to its rated value. In addition, since the load current passes through the semiconductor devices, their rating is high, depending upon the load current.

❖ **System 2:**

The schematic diagram of System 2 is shown in Figure 7. In this system, the load is directly connected to the generator terminals. The value of the excitation capacitor is selected to generate the rated voltage of SEIG corresponding to no-load condition. Under increasing loads, the additional demand of reactive power is provided by the VSI system [17]. Thus the generator voltage will not exceed the rated value. Hence pitch angle control is not required.

The value of the constant dc voltage, input to the inverter, must be greater than twice the phase voltage [18].

As the load is varied, the output generated voltage is adjusted by controlling the reactive power via modulation index control.

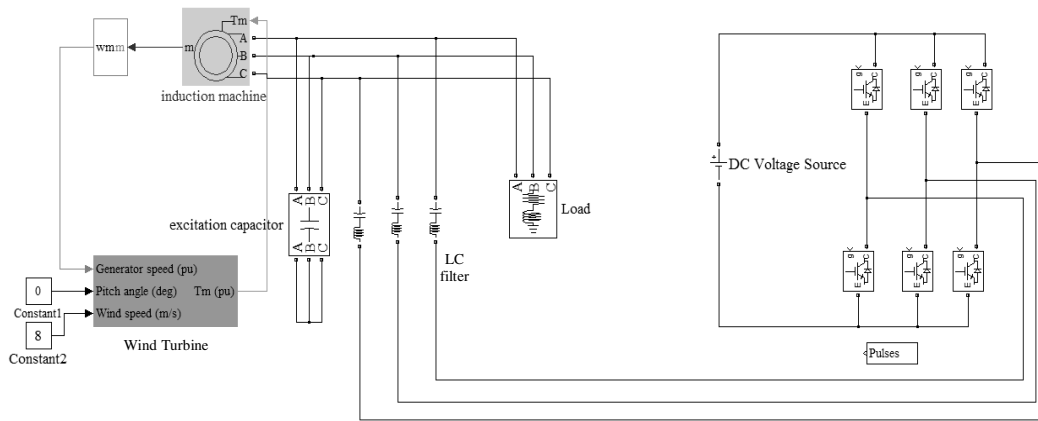

FIGURE 7: System 2.

The output voltage obtained from the inverter is not sinusoidal. For that an LC filter is used to improve the output voltage wave shape. In this system, MI = 0.69 for full-load condition. The load voltage is found to be the rated one as shown in Figure 8. This, itself, is the generated voltage.

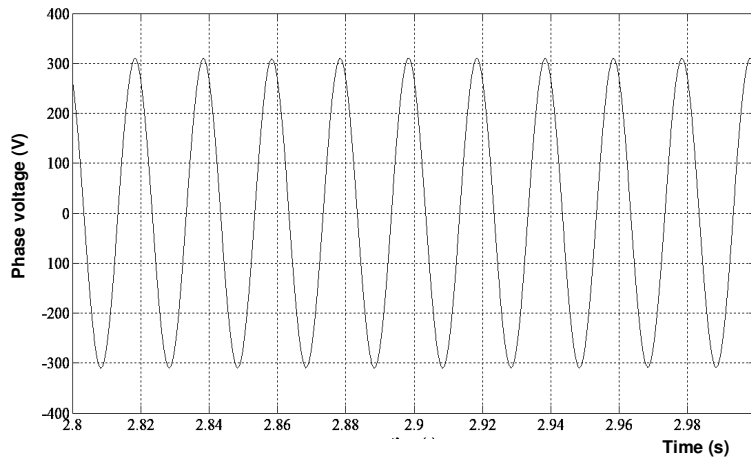

FIGURE 8: Variation of load or generator Phase voltage (System 2).

Table 3 illustrates the relationship between the modulation index and the load, maintaining rated output phase voltage. The frequency is fixed at 50 Hz by the inverter control circuit. Here, wind speed is considered fixed at its base value.

Active load (watt)	Reactive load (VAR)	Modulation index
1600	600	0.645
1400	500	0.625
1200	400	0.615
100	300	0.605
800	200	0.59
600	100	0.576

TABLE 3: Modulation index at different load levels (System 2).

Unlike system 1, the load and generated voltages are maintained at their rated values at all load levels in this system. Thus, pitch control is not required.

The presence of the batteries is the main disadvantage of this system. Their presence increases the cost of the system and limits the turbine power rating. They also require periodic maintenance and replacement. However, these batteries are utilized to help the generator in supplying the load when the wind speed decreases below the base speed.

Since the load current does not flow through the semiconductor devices, their rating is low.

❖ **System 3:**

The schematic diagram of System 3 is shown in Figure 9. Again, here, the load is directly connected to the generator terminals and the excitation capacitors are selected so that the SEIG produces the rated voltage at no-load condition. At other load levels, the additional demand of reactive power is provided by the VSI. Here also, the generator voltage will not exceed the rated value. Therefore, pitch angle control is not required.

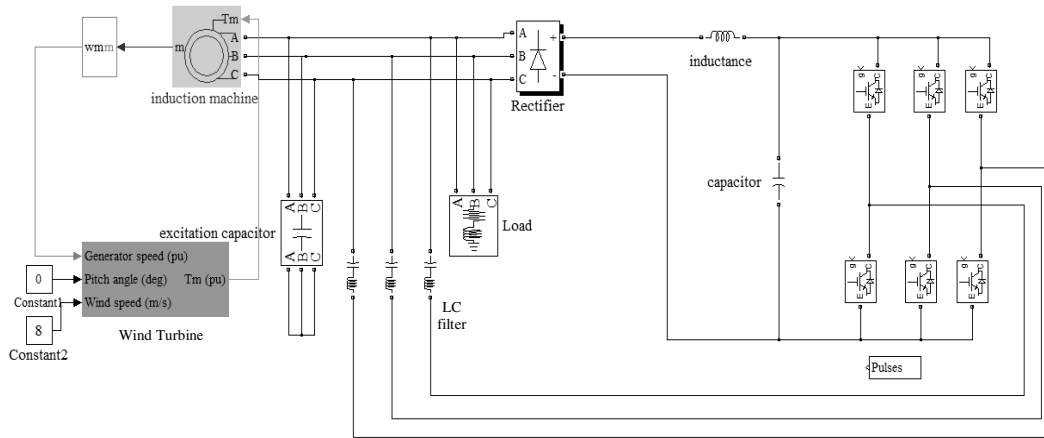

FIGURE 9: System 3.

The dc source used in System 2 is replaced by a 3-phase uncontrolled bridge rectifier in System 3 [19]. The rectifier is fed from the generator output itself. The output of the inverter is connected to the SEIG terminals through an LC filter.

The dc voltage input to the inverter will be disturbed if the load is changed. However, the modulation index MI of the inverter will be adjusted to control the reactive power, bringing the generator voltage and hence the rectifier output dc voltage back to its rated value.

For full-load condition, MI is set at 0.83. The output voltage is found to be at its rated value as shown in Figure 10.

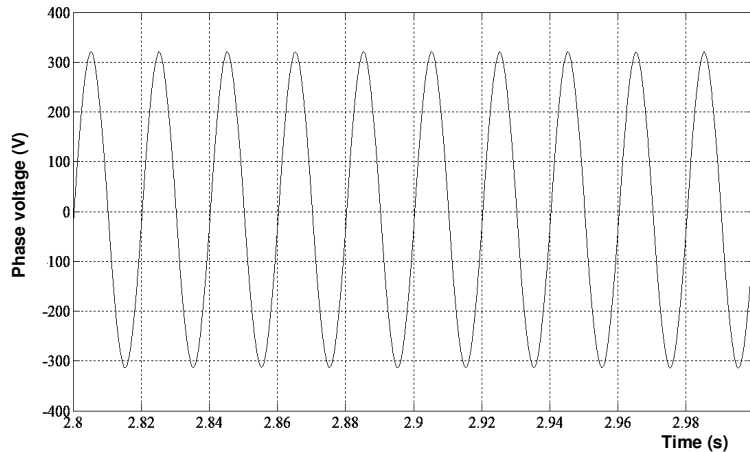

FIGURE 10: Variation of load phase voltage (System 3).

Table 4 shows the relationship between modulation index and the load level so that the load voltage is maintained at its rated value.

Active load (watt)	Reactive load (VAR)	Modulation index
1600	600	0.43
1400	500	0.409
1200	400	0.403
1000	300	0.40005
800	200	0.4
600	100	0.39

TABLE 4: Modulation index at different load levels (System 3).

Again, system 3, maintains rated generated voltages at all load levels. This is done by adjusting the modulation index of the VSI.

At reduced wind speed, the generated voltage decreases. As there are no batteries, compensation of the required reactive power is not possible. Thus, load shedding is necessary to bring the generator voltage back to its rated value. This is the disadvantage of this system.

In this system also, the load current does not flow through the semiconductor devices, therefore, low rating devices may be used.

6. COMPARISON BETWEEN SYSTEM 1, SYSTEM 2 AND SYSTEM 3

The above three systems are now compared and their features are presented in Table 5.

Point of Comparison	System 1	System 2	System 3
Capacitor requirement	Capacitors are selected to obtain rated voltage at full-load condition	Capacitors are selected to obtain rated voltage at no-load condition	Capacitors are selected to obtain rated voltage at no-load condition
Decrease of wind speed	Requires load shedding	Load shedding is not required	Requires load shedding
Reduction of load level	Load voltage remains constant, while generator voltage increases beyond rated voltage. Pitch angle control is necessary	Load voltage as well as generator voltage remain constant. Pitch angle control is not required	Load voltage as well as generator voltage remain constant. Pitch angle control is not required
Battery requirement	No batteries are required	Batteries are essential	No batteries are required
Turbine and generator power rating	Rating of the rectifier-inverter devices should be considered	Number and capacity of the of batteries should be considered	No restrictions on power rating
Cost	Medium	High	Low
Rating of power electronics devices	High	Low	Low

TABLE 5: Comparison of the Three Systems.

The above discussion and Table 5 reveal that System 3 is better than System 1 and 2 from cost and power rating points of view. Compared with System 1, System 3 does not require pitch angle control at reduced load and compared with System 2, System 3 eliminates the dc source (batteries) from its structure.

7. CONCLUSION AND FUTURE WORK

Wind energy is a clean source of energy that does not pollute the environment. In addition, wind energy is free and sustainable. It is one of the fastest growing renewable energies in the world.

Self excited induction generator can produce rated voltage and frequency if the values of the excitation capacitors are properly chosen. These rated voltage and frequency get affected by wind speed and load level disturbances.

Matlab software is used in this paper to simulate the wind driven SEIG considering the effects of wind speed and load variation. Variation of generator voltage and frequency as a consequence of wind speed or load level variation is presented and discussed.

Voltage and frequency regulation can be achieved using rectifier-inverter systems. In this paper, three systems have been presented and discussed.

The three systems have been simulated and the corresponding results are presented, and discussed.

In the three systems, the frequency is maintained constant, at 50 Hz, by fixing the frequency of the reference wave in the control circuit of the inverter.

All the three systems, exhibit capability of regulating the load voltage through modulation index control of the inverter.

The three systems are compared from many aspects highlighting the advantages and disadvantages of each one.

From many aspects, System 3 is found to be better than the other two systems.

For future work, it is suggested that, for the same output power, comparison of the three systems be made from points of view of efficiency, control complexity and cost.

8. REFERENCES

- [1] Gerald M. Angle II, Franz A. Pertl, Mary Ann Clarke and James E. Smith. "Lift Augmentation for Vertical Axis Wind Turbines". International Journal of Engineering, (IJE), Vol, 4, Issue 5, pp. 430-442, 2010.
- [2] R. Bansal, T. Bhatti, and D. Kothari. "A bibliographical survey on induction generators for application of nonconventional energy systems". *IEEE Trans. Energy Conversion*, vol. 18, no. 3, pp. 433-439, Sep. 2003.
- [3] R. Bansal. "Three-phase self-excited induction generators: an overview". *IEEE Transactions on Energy Conversion*, vol. 20, no.2, pp. 292-299, Jun. 2005.
- [4] E. Marra, and J. Pomilio. "Induction-generator-based system providing regulated voltage with constant frequency". *IEEE Transactions on Industrial Electronics*, vol. 47 no.4, pp. 908-914, Aug. 2000.
- [5] W. Chen, Y. Lin, H. Gau and C. Yu. "STATCOM controls for a self-excited induction generator feeding random load". *IEEE transactions on power delivery*, vol. 23, no. 4, Oct. 2008.
- [6] T. Chan. "capacitance requirements of self-excited induction generators". *IEEE Transactions on Energy Conversion*, vol. 8, no. 2, Jun. 1993.
- [7] M. Al-Nuaim. "Study of using induction generator in wind energy applications." Master thesis, King Saud University, KSA, 2005.
- [8] B. Singh, S. Murthy and S. Gupta. "STATCOM-based voltage regulator for self-excited induction generator feeding nonlinear load". *IEEE transactions on industrial electronics*, vol. 53, no. 5, pp. 1437-1452, Oct. 2006
- [9] A. Çaliskan. "Constant voltage, constant frequency operation of a self-excited induction generator." Master thesis, Middle east technical university, Turkey, 2005.

- [10] Y. Chauhan, S. Jain, B. Singh. "A Prospective on Voltage Regulation of Self-Excited Induction Generator for Industry Applications". IEEE Trans. on Industry Applications, vol. 46, no 2, pp. 720-730, Jan. 2010.
- [11] B. Singh, L. Shilpakar. "Analysis of a novel solid state voltage regulator for a self-excited induction generator." IEE Proceedings Generation, Transmission and Distribution, 1998, vol. 145, no. 6, pp. 647-655.
- [12] B. Singh, S. Murthy, S. Gupta. "A voltage and frequency controller for self-excited induction generators". Electric Power Components and Systems, vol. 34, No. 2, pp. 141-157, Feb. 2006.
- [13] T. Chan. "Analysis of self-excited induction generators using an interactive method". IEEE Trans. on Energy Conversion, vol. 10, no 3, pp. 502-507, 1995.
- [14] D. Seyoum. "The dynamic analysis and control of a self-excited induction generator driven by a wind turbine." Ph.D thesis, University of New South Wales, Australia, 2003.
- [15] J. Ardanuy, J. Mora and P. Gutierrez. "Voltage control of isolated self-excited induction generator through series compensation." Technical University of Madrid ISSN 0033-2097, R. 88 NR 1a/2012, pp. 132-136.
- [16] A. Othman. "Simulation and analysis of wind-driven induction generator." MSc thesis, University of Aden, Yemen, 2013.
- [17] A. Hameed, A. Shaltout and M. Abdel-Aziz. "Frequency control of self-excited induction generator in autonomous wind-energy systems." 2nd International Conference on Advanced Control Circuits And Systems, 2008, (ACCS'08).
- [18] B. Saied and H. Mohammed. "Voltage and frequency regulation of a three phase induction generator using voltage source inverter". Al-Rafidain Engineering, vol. 20, no. 1, pp.58-69, Feb. 2011.
- [19] K. Youssef, M. Wahba, H. Yousef and O. Sebakhy. "A new method for voltage and frequency control of stand-alone self-excited induction generator using pwm converter with variable dc link voltage." American Control Conference, Washington, USA, 2008, pp. 2486-2491.

INSTRUCTIONS TO CONTRIBUTORS

The *International Journal of Engineering (IJE)* is devoted in assimilating publications that document development and research results within the broad spectrum of subfields in the engineering sciences. The journal intends to disseminate knowledge in the various disciplines of the engineering field from theoretical, practical and analytical research to physical implications and theoretical or quantitative discussion intended for both academic and industrial progress.

Our intended audiences comprises of scientists, researchers, mathematicians, practicing engineers, among others working in Engineering and welcome them to exchange and share their expertise in their particular disciplines. We also encourage articles, interdisciplinary in nature. The realm of International Journal of Engineering (IJE) extends, but not limited, to the following:

To build its International reputation, we are disseminating the publication information through Google Books, Google Scholar, Directory of Open Access Journals (DOAJ), Open J Gate, ScientificCommons, Docstoc and many more. Our International Editors are working on establishing ISI listing and a good impact factor for IJE.

The initial efforts helped to shape the editorial policy and to sharpen the focus of the journal. Starting with Volume 8, 2014, IJE will appear with more focused issues. Besides normal publications, IJE intend to organized special issues on more focused topics. Each special issue will have a designated editor (editors) – either member of the editorial board or another recognized specialist in the respective field.

We are open to contributions, proposals for any topic as well as for editors and reviewers. We understand that it is through the effort of volunteers that CSC Journals continues to grow and flourish.

IJE LIST OF TOPICS

The realm of International Journal of Engineering (IJE) extends, but not limited, to the following:

- Aerospace Engineering
- Biomedical Engineering
- Civil & Structural Engineering
- Control Systems Engineering
- Electrical Engineering
- Engineering Mathematics
- Environmental Engineering
- Geotechnical Engineering
- Manufacturing Engineering
- Mechanical Engineering
- Nuclear Engineering
- Petroleum Engineering
- Telecommunications Engineering
- Agricultural Engineering
- Chemical Engineering
- Computer Engineering
- Education Engineering
- Electronic Engineering
- Engineering Science
- Fluid Engineering
- Industrial Engineering
- Materials & Technology Engineering
- Mineral & Mining Engineering
- Optical Engineering
- Robotics & Automation Engineering

CALL FOR PAPERS

Volume: 8 - Issue: 5

i. Paper Submission: October 31, 2014

ii. Author Notification: November 30, 2014

iii. Issue Publication: December 2014

CONTACT INFORMATION

Computer Science Journals Sdn Bhd

B-5-8 Plaza Mont Kiara, Mont Kiara

50480, Kuala Lumpur, MALAYSIA

Phone: 006 03 6204 5627

Fax: 006 03 6204 5628

Email: cscpress@cscjournals.org

CSC PUBLISHERS © 2014
COMPUTER SCIENCE JOURNALS SDN BHD
B-5-8 PLAZA MONT KIARA, MONT KIARA
50480, KUALA LUMPUR
MALAYSIA

PHONE: 006 03 6204 5627
FAX: 006 03 6204 5628
EMAIL: cscpress@cscjournals.org