

INTERNATIONAL JOURNAL OF
ENGINEERING (IJE)

ISSN : 1985-2312

Volume 13 • Issue 1 • February 2021
Publication Frequency: 6 Issues / Year

CSC PUBLISHERS
<http://www.cscjournals.org>

INTERNATIONAL JOURNAL OF ENGINEERING (IJE)

VOLUME 13, ISSUE 1, 2021

**EDITED BY
DR. NABEEL TAHIR**

ISSN (Online): 1985-2312

International Journal of Engineering is published both in traditional paper form and in Internet.

This journal is published at the website <https://www.cscjournals.org>, maintained by Computer Science Journals (CSC Journals), Malaysia.

IJE Journal is a part of CSC Publishers

Computer Science Journals

<https://www.cscjournals.org>

INTERNATIONAL JOURNAL OF ENGINEERING (IJE)

Book: Volume 13, Issue 1, February 2021

Publishing Date: 28-02-2021

ISSN (Online): 1985-2312

This work is subjected to copyright. All rights are reserved whether the whole or part of the material is concerned, specifically the rights of translation, reprinting, re-use of illustrations, recitation, broadcasting, reproduction on microfilms or in any other way, and storage in data banks. Duplication of this publication of parts thereof is permitted only under the provision of the copyright law 1965, in its current version, and permission of use must always be obtained from CSC Publishers.

IJE Journal is a part of CSC Publishers

<https://www.cscjournals.org>

© IJE Journal

Published in Malaysia

Typesetting: Camera-ready by author, data conversion by CSC Publishing Services – CSC Journals, Malaysia

CSC Publishers, 2021

EDITORIAL BOARD

ASSOCIATE EDITORS (AEiCs)

Associate Professor Cheng-Xian (Charlie) Lin

Florida International University
United States of America

Professor Tarek M. Sobh

Lawrence Technological University
United States of America

EDITORIAL BOARD MEMBERS (EBMs)

Dr. Jingchao Zhang

University of Nebraska Lincoln
United States of America

Dr. Rachmadian Wulandana

State University of New York (SUNY) at New Paltz
United States of America

Dr. Xing-Gang Yan

University of Kent
United Kingdom

Dr. Reza Shadnam

KPMG
Canada

Associate Professor Miladin Stefanovic

University of Kragujevac
Serbia and Montenegro

TABLE OF CONTENTS

Volume 13, Issue 1, February 2021

Pages

- 1 – 11 Image Processing Based Detecting and Tracking for Security System
Atiq Ur Rehman, Naqeeb Ullah, Naeem Shehzad, Syed Agha Hassnain Mohsan
- 12 – 47 Novel Cost-effective Technique for Continued Operation of Electrical Equipment During
Voltage Sag
Shiva K. Sadula, Rajab Chaloo, Xingang Fu, Shuhui Li

EDITORIAL PREFACE

This is the *First Issue* of Volume *Thirteen* for International Journal of Engineering (IJE). The Journal is published bi-monthly, with papers being peer reviewed to high international standards. The International Journal of Engineering is not limited to a specific aspect of engineering but it is devoted to the publication of high quality papers on all division of engineering in general. IJE intends to disseminate knowledge in the various disciplines of the engineering field from theoretical, practical and analytical research to physical implications and theoretical or quantitative discussion intended for academic and industrial progress. In order to position IJE as one of the good journal on engineering sciences, a group of highly valuable scholars are serving on the editorial board. The International Editorial Board ensures that significant developments in engineering from around the world are reflected in the Journal. Some important topics covers by journal are nuclear engineering, mechanical engineering, computer engineering, electrical engineering, civil & structural engineering etc.

The initial efforts helped to shape the editorial policy and to sharpen the focus of the journal. Started with Volume 13, 2021, IJE will be appearing with more focused issues. Besides normal publications, IJE intend to organized special issues on more focused topics. Each special issue will have a designated editor (editors) – either member of the editorial board or another recognized specialist in the respective field.

The coverage of the journal includes all new theoretical and experimental findings in the fields of engineering which enhance the knowledge of scientist, industrials, researchers and all those persons who are coupled with engineering field. IJE objective is to publish articles that are not only technically proficient but also contains information and ideas of fresh interest for International readership. IJE aims to handle submissions courteously and promptly. IJE objectives are to promote and extend the use of all methods in the principal disciplines of Engineering.

IJE editors understand that how much it is important for authors and researchers to have their work published with a minimum delay after submission of their papers. They also strongly believe that the direct communication between the editors and authors are important for the welfare, quality and wellbeing of the Journal and its readers. Therefore, all activities from paper submission to paper publication are controlled through electronic systems that include electronic submission, editorial panel and review system that ensures rapid decision with least delays in the publication processes.

To build its international reputation, we are disseminating the publication information through Google Books, Google Scholar, J-Gate, ScientificCommons, Docstoc and many more. Our International Editors are working on establishing ISI listing and a good impact factor for IJE. We would like to remind you that the success of our journal depends directly on the number of quality articles submitted for review. Accordingly, we would like to request your participation by submitting quality manuscripts for review and encouraging your colleagues to submit quality manuscripts for review. One of the great benefits we can provide to our prospective authors is the mentoring nature of our review process. IJE provides authors with high quality, helpful reviews that are shaped to assist authors in improving their manuscripts.

Editorial Board Members

International Journal of Engineering (IJE)

Image Processing Based Detecting and Tracking for Security System

Atiq Ur Rehman

*Department of Electronic Engineering
BUIITEMS,
Quetta, 87300 Pakistan*

atiqkhantareen@gmail.com

Naqeeb Ullah

*Department of Electronic Engineering
BUIITEMS,
Quetta, 87300 Pakistan*

naqeeb.ullah@buitms.edu.pk

Naeem Shehzad

*Department of Electrical Engineering,
COMSATS (Lahore) Campus,
Lahore 53400, Pakistan*

naeemshehzad@ciitlahore.edu.com

Syed Agha Hassnain Mohsan

*Optical Communications Laboratory
Zhejiang University,
Zhoushan, 316000, China*

hassnainagha@zju.edu.cn

Abstract

Security systems are getting more attention and importance. Numeral security arrangements based on sensors and wireless communication are available in the form of mechanical and electronic applications. These systems are used widely in banks and government offices. However, these traditional systems lack qualities like they cannot examine, track the suspect and generate the alarm simultaneously. Thus, it is difficult to expand these systems with the help of the sensors because of the complexity of the algorithms used. Hence, viewing these points, this paper provides a security system based on Image Processing, which does not only inform the host side at the runtime through alarm but also detects and tracks the present situation by locating the target. The Optical Flow technique of image processing is used to detect using motion analysis of two consecutive frames from the imaging source. The block analysis determines the tracking capabilities of the system by the property of Good Features to track. The wireless link between the imaging sources is established through XAMPP. While the functionality of the alarm is performed at the commencement of the detection process. The results relating to the process of detecting, tracking and generating alarm simultaneously are encouraging and will help to increase the efficiency of the security systems.

Keywords: Detection, Embedded Systems, Image Processing, Optical Flow Technique, Tracking.

1. INTRODUCTION

The security of public gathering spaces, banks, and large events are crucial for the smooth functioning of public and government activities at all level. People have a profound trust in any provided areas of well-being just by keeping the core of security in their minds. Henceforth, keeping the former points into assessment, the security arrangements are done accordingly in order to ensure the safety and order of that specific section. Thus, these schemes of security vary from section to section in order of priority and threat. Moreover, these systems are divided into monitored security systems: connected with a security agency and non-monitored security

systems: without any connection with the security agency. Similarly, these, schemes of security can be in the form of machinery, human force, or electronic applications.

Many governmental and non-governmental agencies and institutions are working to find the ultimate solution for this cause. Moreover, these agencies and institutions have succeeded by far most. But still, there are areas, which are breached and damaged despite their high alert security systems. Because of this, the higher profile regions and departments have concerns about their security, which needs to be protected and secured from any type of intruder or loss such as the hospitals, plant protection, schools, governmental and non-governmental places, department store, residential areas and parking. Henceforward, these traditional security systems rely on motion sensors, IR sensors, and CCTV cameras to observe a suspect, individual and ongoing activity and require the human workforce to track continuously the images [1]. The technologies used in these security systems are of diverse behaviors intended for different jobs according to their credibility and nature [2]. Generally, the failure of the security systems can be attributed to my reasons such as human error, system glitch, criminal attack, system overload, and the shortage of the power supply.

Usually, the CCTV cameras for crime preventions in the factories' warehouses, and banks merely record the situation and do not notify the host side at runtime [3][4]. This paper provides a security system based on Image Processing helping in removing the human error, informing the host side at the runtime through an alarm, detecting and tracking the present situation by locating the target. Moreover, it also provides the advantage of wireless communication between the imaging sources in cases of a wide area coverages. The working procedure of the system is as that any intruder activity within the restricted place will be captured by the imaging source, based on which the alarm will be generated and further commands of detecting and tracking will be initiated. Likewise, large area coverage is possible in this said project as a second imaging source is wirelessly connected to the main imaging source. Apart from this, a sequence of a password is issued to the authorities helping them to roam in the restricted place without recognizing them as intruders.

2. LITERATURE REVIEW

These days the tracking of objects, for example, individuals or vehicles, coming all through specific spaces is constantly a significant issue in security and operation management. For example, in a shopping center, following the number of clients may help the market arranging, staff organization, and tracking the number of staff individuals may help in the workforce. In addition, object tracking for spots, for example, banks, buildings, and streets may improve traffic control. In general, the object tracking is possible by utilizing entryway counters, or infrared sensor to recognize objects coming all through spaces. Conventionally object tracking methods require a camera above or the entrance/exit way of a place to capture the images. However, these approaches are expensive and require human operator observers who detect any suspicious individual and therefore, challenging to obtain a prior knowledge about all objects in real-time [5][6]. Therefore, a real-time tracking and detecting system is required to detect an unauthorized person in a prohibited area and alarming the security system at the same time

A GSM based home security system includes control panel, door [7], and windows sensors to monitor both coming in and out from the house. These systems use wireless communication to receive the SMS from a cell phone and observe the safety and ensure the security of the home by an SMS [8]. A Zigbee based parameter monitoring and controlling system using microcontrollers are used to track and secure the environment of industries [9][10]. However, these systems have no capability to analyzes the suspect and generate a real-time response. Moreover, it is very difficult to expand the security system by adding several sensors because of the complexity of the algorithm of the system. Similarly, the present bank security system focuses only on the security of lockers and has a limited level of a security system. The digital cameras are used only for monitoring and require the manual approach to inform the security [11]. Therefore, image processing-based tracking and detecting system is required for security purpose that alerts the security through a certain alarm in case of any uncertainty [12][13][14].

Likewise, the security of the border and coastal area is of huge importance and cannot be controlled and observed by the gaze of the human eye. A security system based on the combination of image processing and Support Vector machine is used to overdue this process and detect the intrusion of the unauthorized ships [15].

3. SYSTEM CONFIGURATION

The proposed system configuration makes the system cost-effective, reliable, and flexible in performance. The block diagram of the proposed research work is illustrated in Fig.1.

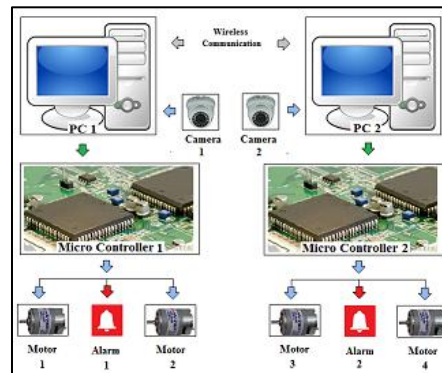

FIGURE 1: Block Diagram of the system consisting of two same modules with a wireless link as a source of communication between them.

A webcam is the main component, which detects a change in its field of view (FOV) connected with the PC for its working and display. A microcontroller is used to control the motors both in terms of pan and tilt. Further by using the technique of motion control, provides the capability to track the subject of motion along with sending of an alarm signal.

4. METHODOLOGY

The proposed detecting and tracking system makes use of image processing and its subclasses such as the Optical Flow method, Canny algorithm and Block analysis, which helps in the achievement of the results as detecting, tracking, and motion control. A flow chart of the proposed system is shown in Fig.2.

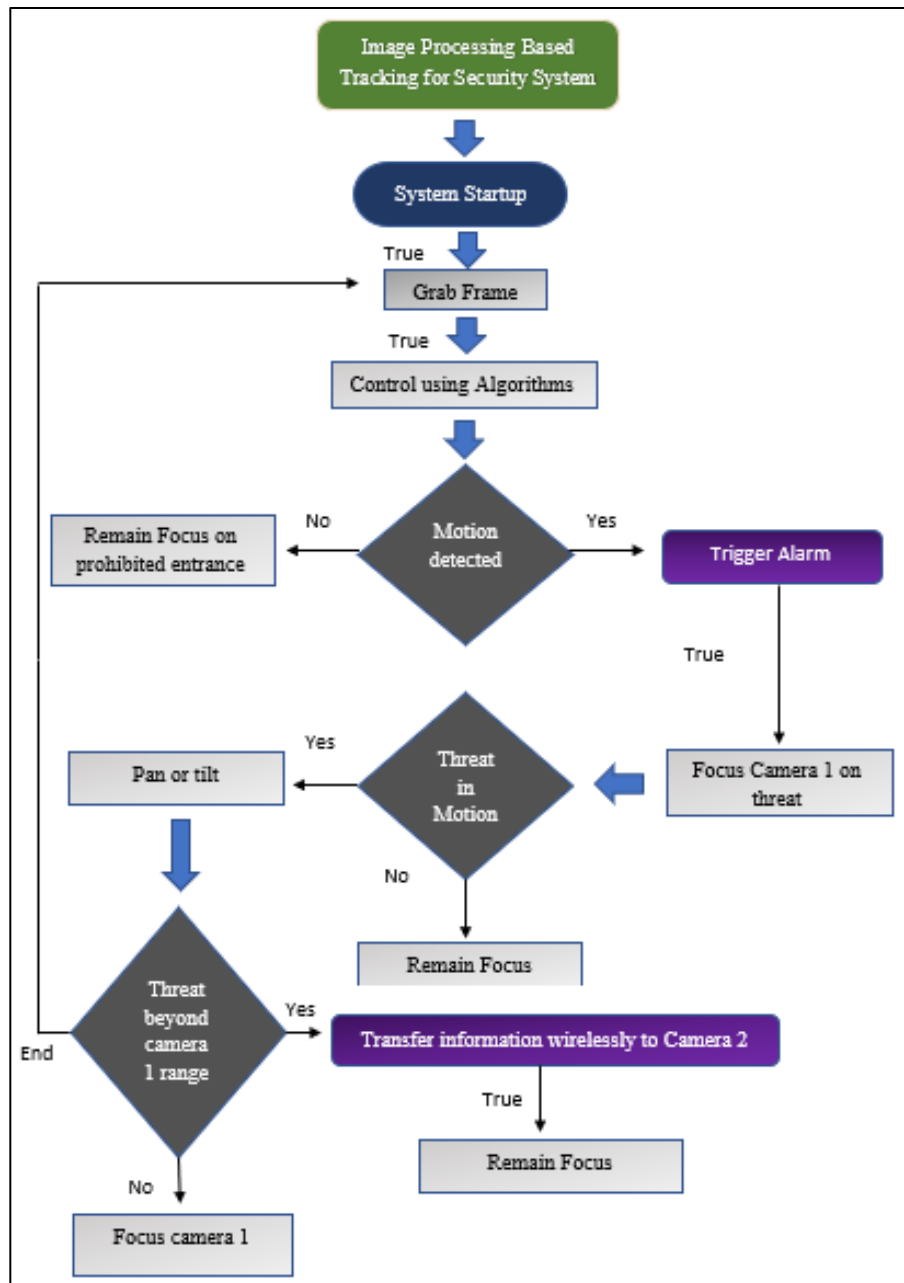

FIGURE 2: Flow chart of the proposed system.

4.1 Optical Flow

Among the parts of the segmentation, a technique to extract information and perform the action according to the requirement is the optical flow method. In this step of the segmentation two or more consecutive frames are taken. Moreover, the pixels are tracked from frame to frame in single mode or can be tracked in the cluster form as well [16]. Firstly, the images are converted into greyscale to identify the change and track the object easily. The process on both of them is performed as such that the new image is compared with the background image. However, this process is also known as the Thresholding process because of applying the values to the produced change in the background as described through Eq. (1).

$$\begin{array}{l} 1 \quad D_i > T_i \\ 0 \quad D_i > T \end{array} \quad (1)$$

Where D_i - Change between two connective frames and T_i – Threshold value.

A filter is used to make the process quick and flexible to detection of the change. Moreover, the accuracy of the detection depends upon the size of the subject, its background, connection and distance during the detecting process. A field of view (FOV) of the camera can be easily detected by comparing the two consecutive frames of video streaming to detect the change between them in terms of the change in single or cluster of pixels.

4.2 Motion Control

The computer or the processing unit capable enough to respond as fast as possible especially as the speed is a critical point. the following procedures are applied [17].

4.2.1 Block Analysis: This block analysis is the method that tracks the object based on the Good Features to track the subject extracted from the OpenCV. Thus, various blocks are being created during the tracking process. Now to select the block a condition is applied to select the block with the highest value.

4.2.2 Finding Intensity Gradient: After smoothing the Image, it is again filtered to get the derivatives of the image both in the vertical and horizontal directions most probably first derivatives. Thus, the direction, as well as the gradient of the pixel, can be easily determined by using the Eq. (2) and Eq. (3) respectively.

$$Angle = \tan^{-1} \left(\frac{G_y}{G_x} \right) \quad (2)$$

$$Edge Gradient = ((G_x^2 + G_y^2)^{1/2}) \quad (3)$$

Where G_x is the Horizontal direction and G_y is the Vertical direction. The direction of the gradient is always perpendicular to the edges and is rounded to one of four angles to represent the horizontal and vertical directions along with the two diagonal directions.

4.2.3 Threshold Values: The intensity gradient value of each edge is comparing with the maximum and minimum values of the threshold. If the value of the intensity gradient is more than the maximum threshold value, it will be considered as a sure edge. While the edges having values of intensity gradient between the minimum and maximum values of the threshold will be considered as edges only if they are connected to the sure edges. Further those edges are neglected which are not connected to the sure edge or having a value less than the maximum threshold value as determined for the process [17]. After the selection of the specific block, its center point will be determined based on which the motion will be controlled as the cameras will keep the target in their center. As illustrated in Fig. 3.



FIGURE 3: Center of the block is designed, as shown by a red spot.

The center of the block is identified by a red spot in the center. Hence based on the motion of the object, the motion of the cameras will be controlled as when to pan and tilt.

4.3 Motor Delays

However, the delay in the motion of the motors does wholly depends upon the movement of the subject, the processing speed of the microcontroller, its delays, and time associated with its responsively. The control structure of the motors is shown in Fig. 4.

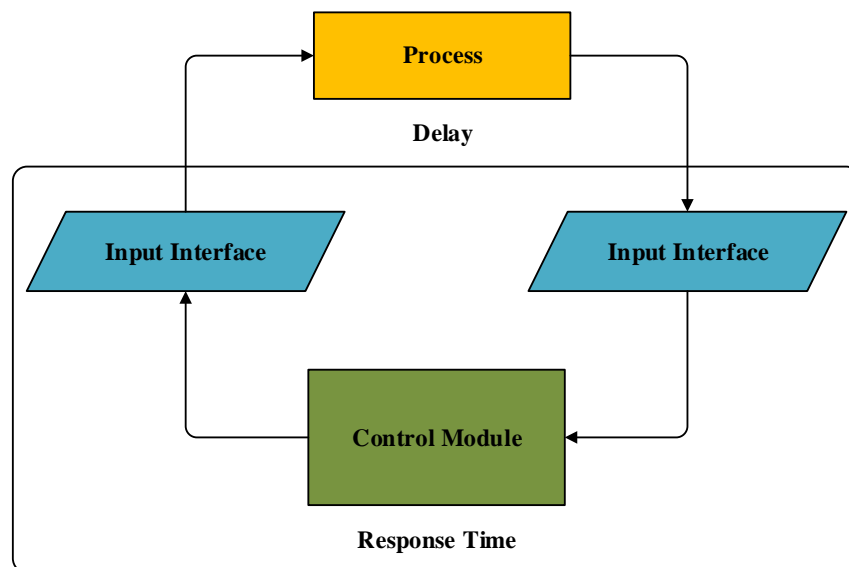

FIGURE 4: Motor delay control for the purpose of the precise motion of the motors w.r.t camera.

By motor delay control the process can be made more responsive and quicker by decreasing the size of the image, as a smaller number of pixels will be involved, with less memory transportation between the controllers and imaging source during the process of live surveillance.

4.4 Wireless Communication

In this modern era, more preference is given to the systems that are compact, reliable, and flexible. Thus, looking at the advantages of wireless communication, we decided to establish a wireless link between the two modules of the project rather than the traditional way of

communication. Hence, for this purpose, we are using Wi-Fi as a source of wireless communication between the two modules by using the same IP address on two different computers through the XAMPP software [18]. The need for wireless communication is needed, when the threat goes out of the boundary of camera 1 of module 1, the information of the threat will be transferred wirelessly to the module 2. Hence the position of the camera 2 of module 2 will track the threat onwards. Wireless communication between the camera's covering a vast area and without the need for extra wiring. Thus, benefitting the cut in the cost. Password for the authorized personals to detect and track them in the secured area without generating the alarm.

5. RESULTS

This section of the paper presents the results obtained during successful running of the system as given below.

5.1 Detection

To detect the face using the property of the Good Features to Track. The proposed system can detect any type of the object within the installed area up to 12 feet approximately by one module. While the time interval for the system to detect any unauthorized entry is about 1.5 seconds as illustrated in Fig. 5.

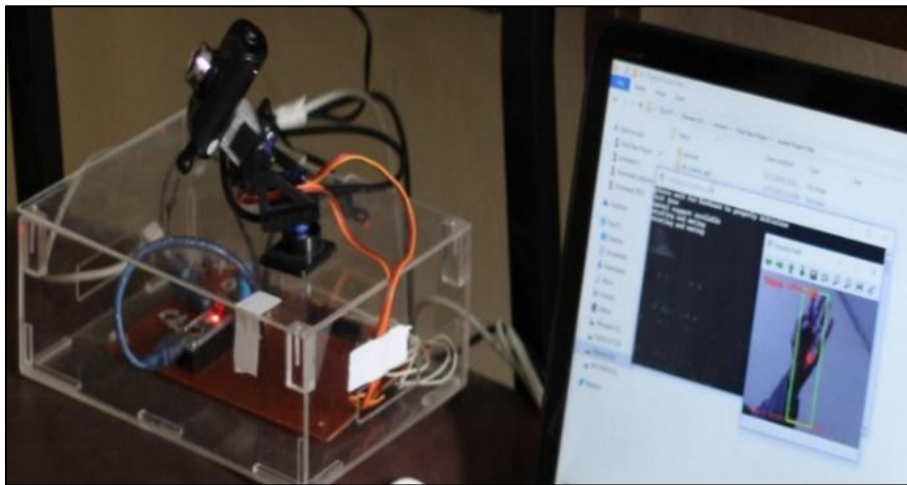

FIGURE 5: Detection property of the system.

5.2 Tracking

Motion of the subject within the prohibited region is accomplished with pan and tilt the camera with the help of servo motors. This function of the project works as whenever there is any subject of the motion, it will be tracked until the last range of distance value is achieved by the camera which is approximately 12 feet after onward the subject of motion is tracked by the camera of the second module after communicating through the established wireless link between them. The following observations were concluded which are mentioned with the help of graphs.

5.2.1 Distance: The distance from the object is inversely proportional to the detection and tracking properties of the system as shown in Fig. 6.

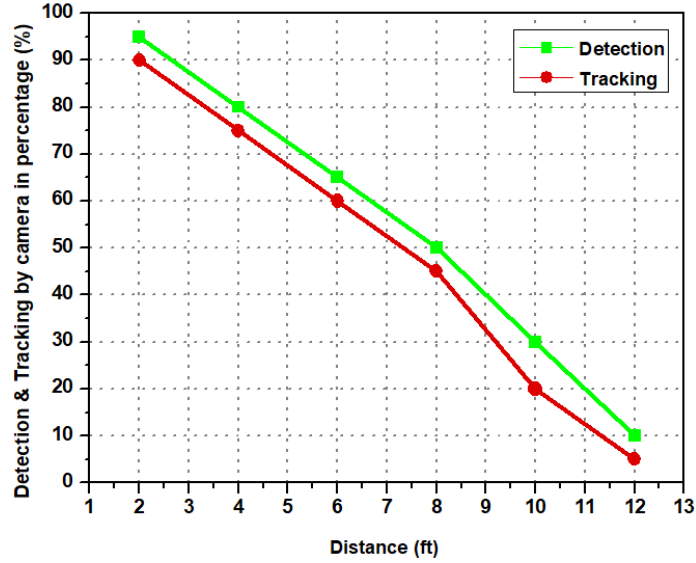

FIGURE 6: Detection and tracking by camera vs. distance.

5.2.2 Light Intensity: Light intensity is among the main factors which will greatly affect the working of the system both in terms of detection and tracking of the object through the camera. After running the project in different light intensities, the following observations are achieved shown in Fig. 7.

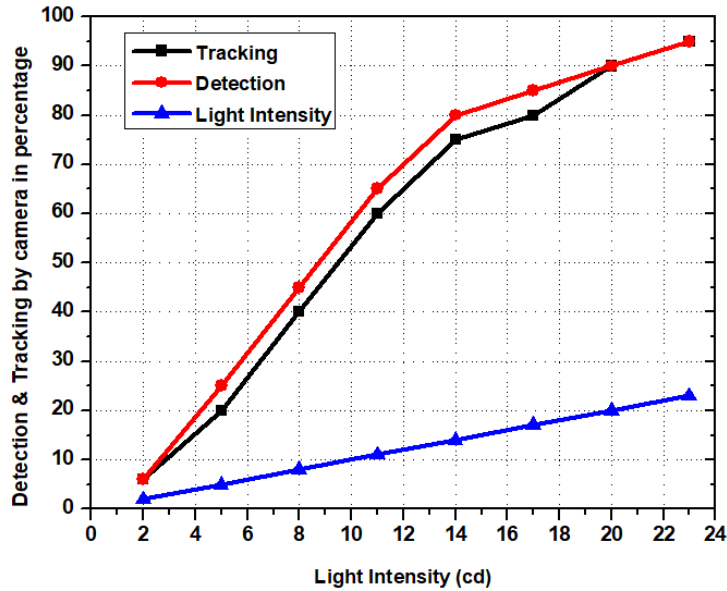

FIGURE 7: Detection and tracking vs. light intensity.

5.2.3 Speed: The results achieved as illustrated in Fig. 8. with the help of the human motion and a stopwatch representing detecting and tracking accuracy in percentage on the y-axis and speed in meters per second on the x-axis respectively.

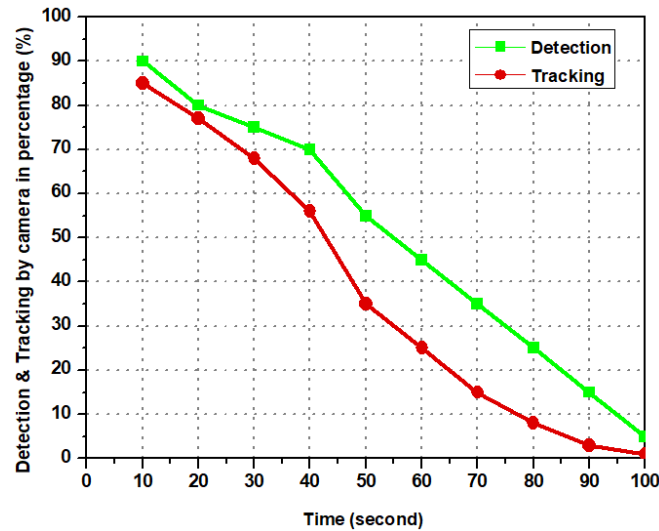

FIGURE 8: Detection and tracking by camera vs. speed,

Wireless communication between the camera's covering a vast area and without the need for extra wiring. Thus, making the system cost-effective. Password for the authorized personals to detect and track them in the secured area without generating the alarm. The proposed method is designed to track and detect a single object at a time. For multiple artifacts, however, a complicated algorithm will be required. The proposed system can be further improved using infrared lighting while utilizing the system at night time. In the case of blurry progression of the image sources, the advanced algorithms of the image processing can be used i.e. Grasshopper optimization [19].

6. CONCLUSION

In this paper, image processing-based detecting and tracking system is proposed for monitoring public gathering venues like railway stations, banks, airports, and stadiums. The proposed system uses the Optical flow method with the Canny algorithm along with the property of Good Features with pan and tilt of the camera to track and detect any type of the moving object. Moreover, an alarm will be generated automatically, whenever there is an unauthorized entry into the entrance prohibited region. Moreover, in this paper, it has observed that distance between the object and tacking system is inversely proportional to the detection and tracking properties of the system. However light intensity of the light is directly proportional to detection and tracking accuracy. Though, the speed of the moving object is also inversely proportional to the accuracy of the detecting and tracking system. Similarly, the working of the system is limited in harsh environmental conditions i.e. fog, rain and dust if used outside. Likewise, the properties of the model will be restricted at night corresponding to the property of the light as discussed.

In the future, the accuracy and performance can be enhanced by implementing artificial intelligence and advanced moving object detection methods. Apart from these, the system in the future would enable detection and tracking of multiple subjects at once, which is limited to one for the time being. Moreover, the system can be made into multiple modules consisting of several imaging sources, which will help in vast area coverage. Similarly, the accuracy of the system regarding detecting and tracking can be increased further with the installation of the white background and higher luminosity. The artificial intelligence will further help in the future in a comparison between human beings, animals, and materials based on their specific shapes, colors, and sizes. The system would therefore be a significant advancement in the field of security systems to protect areas of banks, airports, car parks, and factories. In addition, the system's password-protected property would allow the authorized staff to roam freely without creating an alarm. While in roaming, the properties such as detection and tracking will be intact of the authorized staff within the area.

7. REFERENCES

- [1] K. Salunkhe, P. Rajaram, S. Raut, and S. Kurle. "Real-time Activity Detection & Recognition in Video." *International Journal of Future Generation Communication and Networking*, Vol. 13, pp. 76- 83, May. 2020.
- [2] J. Wolfendale. "Terrorism, security, and the threat of counterterrorism." *Studies in Conflict & Terrorism*, vol. 30, pp. 75–92, Dec 2006.
- [3] E. L. Piza, B. C. Welsh, D. P. Farrington, and A. L. Thomas. "CCTV surveillance for crime prevention: A 40-year systematic review with meta-analysis." *Criminol. Public Policy*, vol. 18, no. 1, pp. 135–159, 2019.
- [4] G. Alexandrie. "Surveillance cameras and crime: a review of randomized and natural experiments." *Journal of Scandinavian Studies in Criminology and Crime Prevention*, vol. 18, no. 2, pp. 210–222, 2017.
- [5] N. N. Swathi, K. Alekhya, D. Pavithra and D. Kalyan Babu. "Implementation of Vision Based Intelligent Home Security System Using ARM7." *International Research Journal of Engineering and Technology*, vol. 4, no. 02, pp. 2395-0056, 2017.
- [6] M. Dinesh and K. Sudhaman. "Real time intelligent image processing system with high speed secured Internet of Things: Image processor with IOT." *International Conference On Information Communciation And Embedded System (ICICE2016), Chennai*, 2016, pp. 1-5.
- [7] A. B. Dorothy, S. B. R. Kumar, and J. J. Sharmila. "IoT Based Home Security through Digital Image Processing Algorithms." *2017 World Congress on Computing and Communication Technologies (WCCCT)*, Tiruchirappalli, 2017, pp. 20-23.
- [8] Morbale, J. S., A. Kumari, H. Mishra, K. Sachan. "GSM Based Home Automation, Safety and Security System Using Android Mobile Phone," *Internation Journal of Current Research*, vol. 8, no. 03, pp. 28239-28243, 2016.
- [9] N. Ullah, M. S. Akram, H. U. Buzdar, A. U. Rehman, M. A. Khan, and S. Khan. "ZigBee-based Parameter Monitoring and Controlling Scheme for Multiple DC Motors," *Indian Journal of Science and Technology*, vol. 13, no. 6, pp. 725–734, 2020.
- [10] H. Yetis and M. Karakose. "Image processing based anomaly detection approach for synchronous movements in cyber-physical systems." *2018 23rd International Scientific-Professional Conference on Information Technology (IT)*, Zabljak, 2018, pp. 1-4
- [11] M. T. Awad, S. M. Aldaw, S. M. Aldaw and B. A. r. Osman. "Video Security System for Intrusion Detection," *2019 International Conference on Computer, Control, Electrical, and Electronics Engineering (ICCCEEE)*, Khartoum, Sudan, 2019, pp. 01-04.
- [12] R. Socha and B. Kogut. "Urban Video Surveillance as a Tool to Improve Security in Public Spaces," *Sustainability*, vol. 12, pp. 1-12, 2020.
- [13] K. N. Pentaiah and P. J. Ker. "Development of a Microcontroller-based Portable Surveillance System with User Alert Notification." *Journal of Environmental Science and Technology*, vol. 10, pp. 80-87, 2017.
- [14] S. Tanwar, P. Patel, K. Patel, S. Tyagi, N. Kumar, and M. S. Obaidat. "An advanced Internet of Thing based Security Alert System for Smart Home." *2017 International Conference on Computer, Information and Telecommunication Systems (CITS)*, Dalian, 2017, pp. 25-29.
- [15] S. Dugad, V. Puliyadi, H. Palod, N. Johnson, S. Rajput and S. Johnny. "Ship intrusion detection security system using image processing & SVM." *2017 International Conference on Nascent Technologies in Engineering (ICNTE)*, Navi Mumbai, 2017, pp. 1-7,

- [16] S. Blakeman and D. Mareschal. "A complementary learning systems approach to temporal difference Learning." *Neural Networks*, vol. 112, pp. 218-230, 2020.
- [17] S. Kyle, "Human and Group Activity Recognition from Video Sequences." PhD thesis, University of York, Heslington, UK, 2016.
- [18] K. V. Kai "Oswald" Seidler, "XAMPP <https://www.apachefriends.org/index.html>." [Online]. Available: <https://www.apachefriends.org/index.html>, [Oct, 15,2020]
- [19] A. Sezavar, H. Farsi and S. Mohamadzadeh. "A Modified Grasshopper Optimization Algorithm Combined with CNN for Content Based Image Retrieval," *International Journal of Engineering*, vol. 32, no. 7, pp. 924-930, 2019.

Novel Cost-effective Technique for Continued Operation of Electrical Equipment During Voltage Sag

Shiva K Sadula

*Tesla
45500 Fremont Blvd
Fremont, CA 94538, USA*

shivakumarsadula@gmail.com

Rajab Challoo

*Department of Electrical Engineering and Computer Science
Texas A&M University-Kingsville
Kingsville, TX 78363-8202, USA*

rajab.challoo@tamuk.edu

Xingang Fu

*Department of Electrical Engineering and Computer Science
Texas A&M University-Kingsville
Kingsville, TX 78363-8202, USA*

xingang.fu@tamuk.edu

Shuhui Li

*Department of Electrical and Computer Engineering
The University of Alabama
Tuscaloosa, AL 35487, USA*

sli@eng.ua.edu

Abstract

This research focuses on mitigating voltage sags at the control level through a cost-effective method using mini dynamic sag corrector at low voltage systems and proposing control level embedded solutions for equipment design and modifying the technical aspects of electrical devices to facilitate the control circuit to ride-through voltage sags. Voltage sags also known as “dips” are a common cause of power disturbances. These are temporary voltage drops below 90% of the nominal voltage caused by a sudden increase in loads or short circuits and faults lasting up to 170ms. Voltage sag in distribution networks can adversely affect sensitive electrical equipment in industrial processes, such as production and manufacturing, resulting in substantial financial losses of up to \$1.5 million/day. Various types of electrical equipment are susceptible to voltage sags but are not limited to power supplies, relays, contactors, variable frequency drives, and programmable logic controllers. In this method, the cost-effective MiniDySCs were installed in the industrial plant to compensate for the missing voltage in the lines during a sag event. Also, modifications to technical aspects of Contactors, Relays, and VFDs are proposed to provide more robust results for the control circuits to ride through voltage sags even up to 40% of the nominal voltage-drop.

Keywords: Voltage Sag, Industrial, Equipment, Control, Power, Cost-effective.

1. INTRODUCTION

This Power quality has been in the technical literature since the 1960s. Since then, there have been many publications on the quality of power, and it has increased significantly over the last decade. Many reasons are given to explain the interest in power quality [1]. Nowadays electrical loads and power electronic devices have become more sensitive to power quality issues. Customers from industries are very concerned about economic losses due to power quality which may affect their processes. There is a need to increase performance criteria to evaluate the power quality supplied.

Around 60% of the time power quality issues are caused due to voltage sags. From figure 1 it can be seen another 40% of power quality issues caused by Voltage swells, Interruptions, and Spikes.

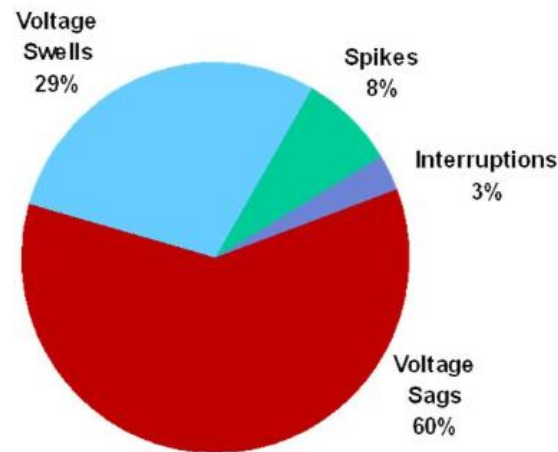

FIGURE 1: Power Quality Issues [1].

The primary issue causing a power quality problem is voltage sag. According to IEEE Std. 1346, 1998 and IEC 61000, 1990, Voltage sags also called voltage dips are defined as a decrease in RMS voltage or current at the power frequency for a short duration of 0.5 cycles to 1 minute or a sudden reduction in voltage at a point in the electrical systems and recovered after a short period, within few seconds [2].

End users were looking for more reliable with high quality and focusing on reducing the malfunction of critical electrical devices. There are some crucial end-users such as production, manufacturing, and commercial buildings need a sine-wave voltage with constant amplitude and frequency, pointed out in [3]. The literature since the 1960s [4] show the efforts and the research towards industrial plants, planning, operation, the sensitive electric loads, also their performances under poor power quality conditions. The sensitive electronic systems for process control are taken for granted in commercial and industrial activities. These new applications needed higher power quality levels. Any power related interruption causing downtime and economic or financial losses were likely to accelerate a study to determine appropriate corrective actions.

Voltage sags also called voltage dips are defined as a decrease in RMS voltage or current at the power frequency for a short duration of 0.5 cycles to 1 minute or a sudden reduction in voltage at a point in the electrical systems and recovered after a short period, within few seconds [5].

The main concern of voltage sags is their effect on sensitive equipment such as relays, contactors, programmable logic controllers and adjustable speed drives, in addition to other power electronic equipment. M. McGranaghan stated and analyzed the voltage sag effects on the industrial process applications [6]. He explained and described the causes and the impact of voltage sags on the sensitive industrial equipment, and he also proposed possible solutions. The author also explained the possible methods for power conditioning the sensitive loads. Voltage sags in industrial production and manufacturing semiconductor equipment can cost as much as \$2 million loss in revenue per day as per an article stated on March 30, 1998, in Semiconductor Business News [7]. Lightning, hurricanes, utility system failures, or internally induced plant events can cause voltage sags. A manufacturing customer on average might see one or two interruptions per year whereas, the same customer may experience over 20 dips per year depending on how many circuits are feeding on a substation. Sag events can affect the operation of production equipment leading to shut down, malfunction, and loss in revenue. These voltage sags measured in magnitude and duration can be defined as temporary voltage drop below 90

percent of the nominal voltage to as low as 20 percent, caused by a sudden increase in loads or short circuits and faults. Typically, sag duration is from 3 to 10 cycles or 50 to 170 milliseconds [7].

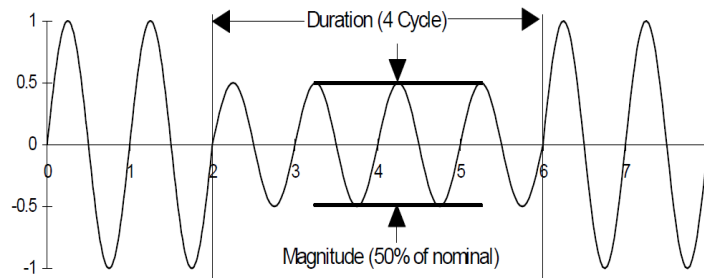

FIGURE 2: Description of voltage sag by Magnitude and Duration [7].

When voltage sag occurs, if the equipment tends to shut down during regular power system operation, then the equipment is said to be incompatible with its electrical environment and have poor quality. We can use the necessary control circuit in every type of equipment. Understanding their response to voltage sags can help tool designers to build and service a more reliable process machine. Many other researchers have recently contributed and focused on issues related to mitigating voltage sags [8], [9], [10], [11], [12], [13], [14].

2. VOLTAGE SAG IMMUNITY STANDARDS

A Semiconductor Equipment and Materials International (SEMI) has developed industrial semiconductor equipment standards that will help the control level equipment to ride through voltage sags. These recommendations were developed to satisfy the semiconductor and manufacturing industry needs. These specifications set minimum voltage sag immunity standards for equipment used in the industry. The voltage sag depth and duration specify immunity. This specification also sets finding and agreeing requirements for pass/fail criteria. SEMI focuses on the equipment which is highly sensitive to voltage sags. This sensitive equipment including but not limited to Power supplies, AC Contactor coils, and AC Relays, Chillers, pumps, blowers, and Adjustable Speed Drives. SEMI conducted many equipment tests through the pass/fail criteria and developed the standards and specifications for the semiconductor equipment to ride through voltage sags.

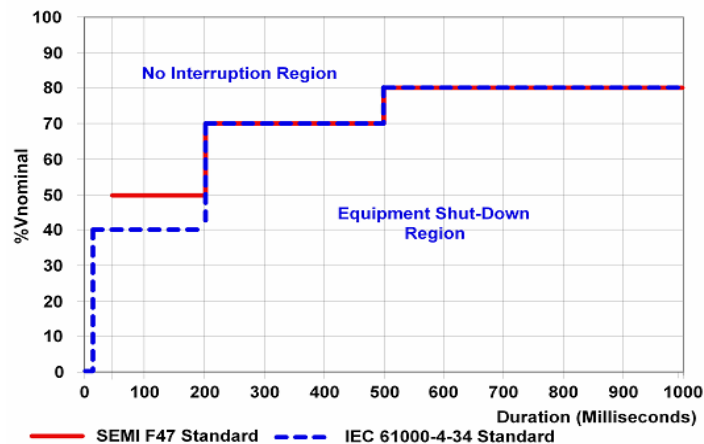

FIGURE 3: Immunity testing levels from IEC 61000-4-11 and 61000-4-34 compared with immunity requirements in SEMI F47 [15].

SEMI has stated their equipment specifications, and standards in SEMI F47 requirements and

SEMI F42 says equipment test requirements. Voltage sag tests conducted by SEMI on 33 tools revealed the most common susceptibility problems in the manufacturing equipment. SEMI examined the weak links found in the semiconductor tools, many of the same mechanisms were responsible for the shutdown of the devices and divided into a category by the percentage of time for a particularly weak link.

Voltage sag susceptibility ranking	Weak link	Overall %
1	EMO circuit: Pilot relay (33%) and Main contactor (14%)	47%
2	DC power supplies: PC (7%), Controller (7%), I/O (5%)	19%
3	3 Phase power supplies: Magnetron (5%), RF (5%), Ion (12%)	12%
4	Vacuum pumps	12%
5	Turbopumps	7%
6	AC Inverter Drives	2%

TABLE 1: Voltage sag susceptibility ranking for specific tools [15].

After testing the equipment, Contactors and Relays were responsible for the tool shutdown 47% of the time. DC power supplies, AC drives, and pumps are also the reasons for the tool shut down but not majority of the time. As a result, the required specifications need to be changed in these tools to help them ride through voltage sags. SEMI has specified the change of specification recommendations to minimize design efforts and testing for these methods to apply to IEC standards. SEMI F47 requires that semiconductor process equipment should tolerate voltage sags connected to the AC power line. They must endure sags to 50% of equipment nominal voltage drop for the duration of up to 200ms, sags to 70% for up to 0.5 seconds, and sags to 80% for up to 1.0 second.

-+-Voltage Sag duration				Voltage Sag
Seconds (s)	Milliseconds (ms)	Cycles at 60hz	Cycles at 50hz	Percentage(%) of equipment nominal voltage
<0.05	<50	<3	<2.5	Not specified
0.05 to 0.2	50 to 200	3 to 12	2.5 to 10	50%
0.2 to 0.5	200 to 500	12 to 30	10 to 25	70%
0.5 to 1.0	500 to 1000	30 to 60	25 to 50	80%
>1.0	>1000	>60	>50	Not specified

TABLE 2: Voltage sag duration and percent deviation from the nominal voltage of equipment [16].

The equipment should continuously operate without any interruption during the conditions identified in the area above a solid black line. There are additional thresholds recommended by SEMI F47 but are not the requirements for the standard. These include that the equipment tolerates sags to 0% for 1.0 cycle, sags to 80% for 10 seconds, and continuous sags to 90%.

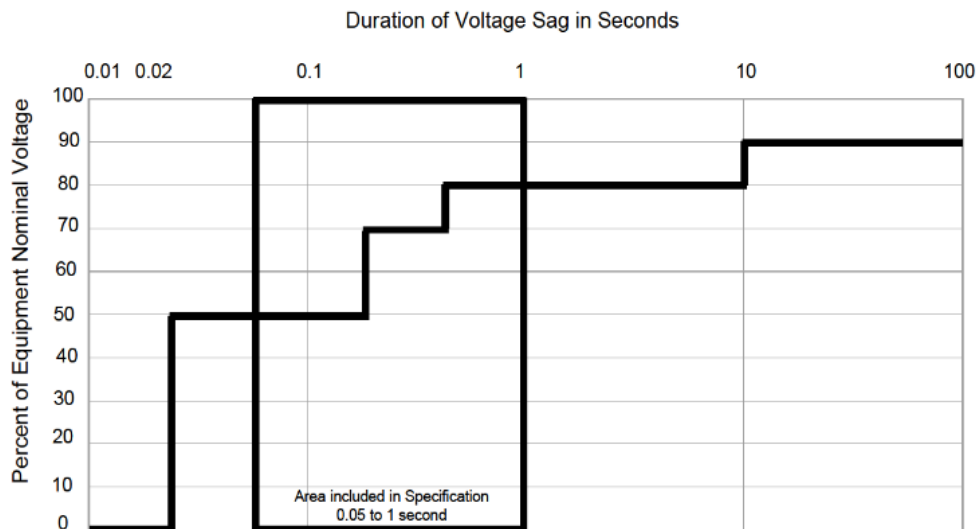

FIGURE 4: Recommended semiconductor equipment voltage sag ride-through capability curve from 0 to 100 seconds [16].

3. SAG MITIGATION TECHNIQUES

Many mitigation techniques available for voltage sags can be found in the technical literature. Authors Johns and Morgan proposed the impact of voltage sags on the industrial equipment that can be mitigated by ride-through coordination [17]. Also, many others suggested a different kind of methods for voltage sag mitigation. Some are by using current-limiting fuses, reducing fault clearing time, by application of power electronic devices, also by using feeder transfer in power distribution systems. The commonly used mitigation technique is to install a new power electronic device. These power electronic devices are of various types. Some of them are Uninterruptable Power Supply, Dynamic Voltage Restorer, and D-STATCOM. These mitigation techniques are beneficial which will mitigate the occurred sags and provide regulated continuous power for the industry for the entire plant. Understanding the operation of these power electronic devices for sag mitigation is an important aspect.

3.1 Uninterruptable Power Supply (UPS)

UPS is an electrical device that provides backup power via battery to a load when regular utility power is lost. Depending on the UPS, some can protect against voltage spikes or power surges that help protect every piece of equipment connected to the UPS. UPS cannot be used for longer durations. Typically, they are only used for short periods to provide critical backup power until an alternate power source is provided. This will be essential when we are relying on electrical equipment to run, and we cannot afford a power outage. Some examples of this might be when we are needing to keep a control cabinet and an industrial application running to make sure that we are monitoring and controlling critical functions of the cabinet. Also, it allows us enough time to save critical data on a computer for instance that might be due to a sudden power outage. If the UPS that we are using does have surge protection that can assist in protecting the equipment against any power surges that can damage that equipment which can be very expensive and time-consuming to replace. They can also act as a bridge while the backup generator is coming online and synchronized with our electrical system. There are two types of UPS, online and standby.

In online UPS, the connected equipment is continuously drawing power from the battery through the converter, so no switching is necessary. Utility power is then used to keep the battery charged continuously, allowing seamless power during an outage and can better protect electrical equipment it is protecting. The advantages of UPS are stable AC voltage and frequency without harmonics supplied to the load. There is no switching between the AC supply and battery; there is

no transfer time or "dead" time. The disadvantages are not cost-effective and much complexity in the system.

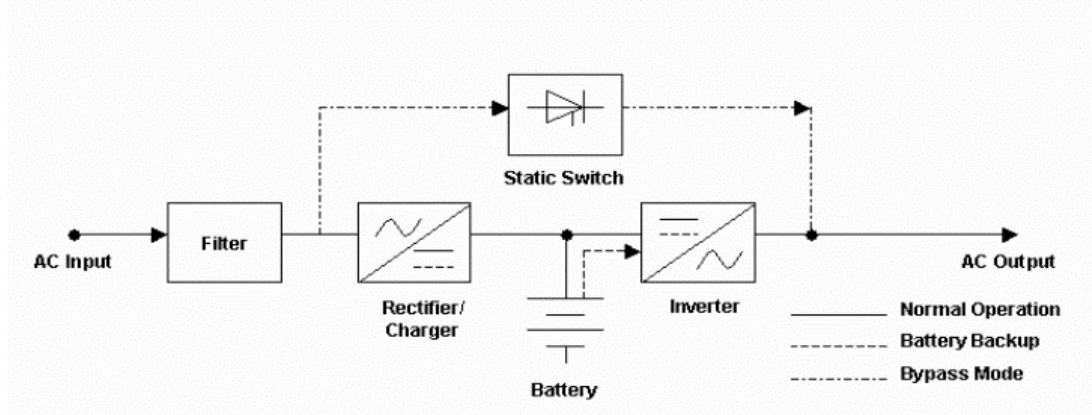

FIGURE 5: Simple Online UPS [18].

In standby UPS or off-line UPS, the normal utility power supplies the protected equipment. When the voltage reduces to a certain level, the UPS will mechanically switch the connected equipment to the inverter located on the UPS. At this point, the UPS will then begin providing power from the battery. The disadvantages are the output voltage is not regulated; there is a transfer time or "dead" time when switching operating modes, there is no protection for harmonics and the system does not protect against any other disturbances other than blackouts.

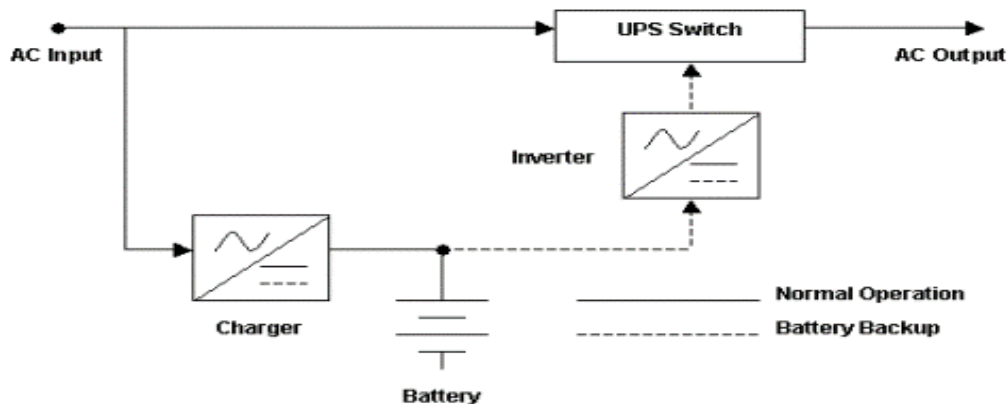

FIGURE 6: Simple off-line UPS [18].

3.2 Dynamic Voltage Restorer (DVR)

A Dynamic Voltage Restorer (DVR) works in a series condition which is known as a series voltage compensator. It works with a voltage source inverter, with an energy storage device such as a battery and some controllers. A DVR detects the voltage sag and compensates so that the sensitive loads which are connected are affected and stay reliable. This technique is useful because it is not complicated, and the results are very useful. A DVR injects a required three-phase voltage with magnitude and frequency in synchronization to the affected voltage due to sags, thus provides a continuously regulated supply.

The amplitude and phasor angle of the injected voltage will be variable. Therefore, it allows controlling the exchange of real and reactive power between the dynamic voltage restorer and the distribution network which leads to the improvement of the complete electrical system. The operation of a DVR is explained in the diagram shown below. The schematic typically illustrates whenever the sag occurs the controllers will detect the unregulated voltage and forward the

information to the injecting transformer controls, thus supplying the regulated power supply to the sensitive loads connected to the secondary distribution of the transformer.

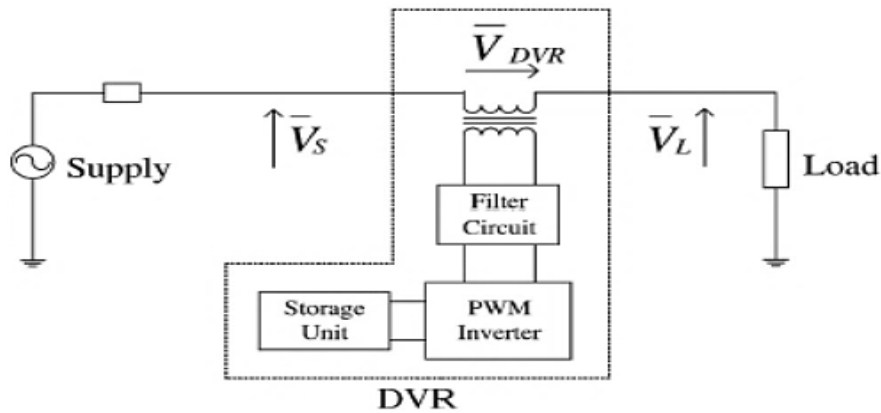

FIGURE 7: Typical DVR structure [18].

3.3 D- STATCOM Technique

The STATCOM is a static compensator. Distribution Static Compensator (D-STATCOM) is used in distribution networks. It is a connected shunt device to the distribution network placed on the busway. It regulates the voltage by either generating or absorbing reactive power. This method can compensate for the bus voltage or line current. The static compensator can be operated in two modes depending on the parameter which it regulates. These types are known as Voltage mode operation and Current mode operation.

In the Voltage mode operation, it can regulate the distorted voltage and supply a pure sinusoidal voltage even if there are any imbalances in the supply voltage. The Current mode operation forces and makes the source current to be balanced sinusoidal wave also if there are harmonics in the load current. When system voltage is low, the STATCOM generates reactive power, and when the system voltage is high, it absorbs reactive power. Thereby, we can say that a STATCOM acts as an inductor or a capacitor depending on the magnitude of the voltage.

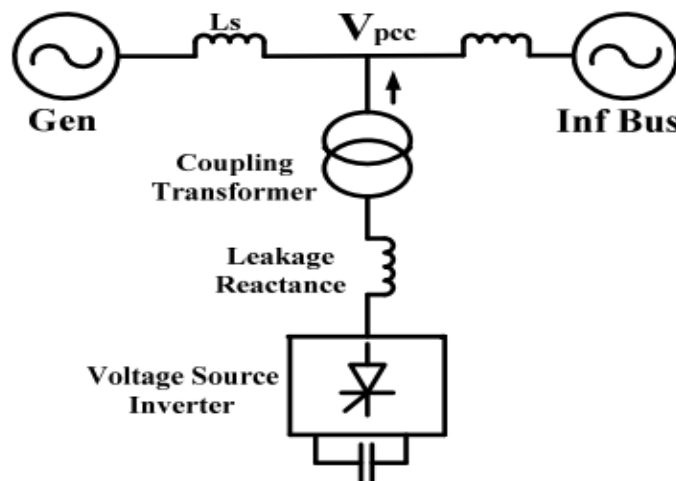

FIGURE 8: D-STATCOM Structure [18].

4. THE INDUSTRIAL PLANT

4.1 Case Study on Industrial Network

The industrial network deals with different levels of medium voltage. So, understanding the network is a very crucial part. Several numbers of loads are fed from the medium voltage transformers. In these loads, there are multiple numbers of motors connected through each distribution panel. These power distribution panels are fed directly from the medium voltage substations. The most critical loads which are sensitive to voltage sags are situated in the central utility building. This building has multiple induction motors that are connected to chillers, high-pressure water heaters, and boilers.

The control panels control these all, and Variable frequency drives protect the motors. VFDs and control panels are very sensitive to interruptions, and they need a continuous power supply to turn on the large machines. So, this makes a good base for the research towards the mitigation of voltage sags.

4.2 Understanding The Electrical Distribution of Factory

The industrial network starts with a 120kV switchgear which is fed from the NV energy utility company. Then later the 120kV is stepped down and transformed to 34.5kV via two delta-ye transformers of 132MVA capacity. This transformed voltage is distributed to the two-individual switchgear, switchgear 701 and 702. From these two switchgears, individual feeders are run to feed the substations. At the substation level, the 34.5kV voltage is again transformed into 480V in the substations through the built-in 4167 kVA transformer. These substations distribute the step-down voltage of 480V to the power distribution panels through a 5000A breaker and then later through distribution panels required voltage is supplied to the tools. Our base location for research is the central utility building; this building has six substations named C01, C02, T01, T02, D01, and P01. The 34.5kV feeders coming into substations C01, C02, T01, and T02 are stepped down to 480V through a 3640 kVA transformer and supplied to the tools which require this voltage. The other two substations D01 and P01 are transformed from 34.5kV to 4160V through a 12.5MVA transformer and then supplied to the tools which require 4160V. There is also an emergency feed of 24.9 kVA coming from the switchyard which feeds these substations. This emergency feed is 24.9kV is stepped down to 480V via 300kVA transformer. This emergency feed is used through a panel A01, whenever there is a downtime in the normal feeders.

5. DYNAMIC SAG CORRECTORS

The sensitive equipment in the industry is fed from all the substations mentioned above. The 480V is supplied to the individual control panel and motors. These control panels have susceptible tools. These vulnerable devices can be contactors, controlled relays, rectifiers, thyristor-controlled motor drives, and adjustable speed drives. These all are very sensitive and susceptible to minimum voltage sags, and some of the equipment is designed with power storage as many manufacturers are doing it. But for the industry cost comes into a question and they buy the general equipment without any additional features. A typical end-user customer does not think of any voltage sag susceptibility when purchasing the equipment. A semiconductor manufacturing industry SEMI F47 and CEBMA both recognized the sensitivity to voltage sags and proposed the standards for input voltage magnitude and duration so that equipment can tolerate the dips [19].

The Dynamic Sag Corrector (DySC) was designed and evaluated first in 1998 to protect the sensitive equipment to voltage sags and for their mitigation. It was designed under certain principles. As we know the cost comes first. It is a cost-effective device that costs less than other mitigating devices that are available in the market. A standard dynamic sag corrector can protect against 92% of the events known by the tests conducted by DPQ [19]. These sag correctors can mitigate sags up to 50% of the nominal voltage drop up to 2 seconds. The size and weight vary on the number of phases. It can go up to 1.5 kVA to 2000 kVA.

A Dynamic sag corrector is typically known as a power conditioning device which is connected in a series-parallel combination and provides significant results towards mitigating voltage sags. The

DySC can protect against voltage interruptions and transients and temporary power losses. There are three types of sag correctors depending on their size and phases.

5.1 Mini Dynamic Sag Corrector (MiniDySC)

The MiniDySC is connected to a single-phase line and is thus called a single-phase MiniDySC. It is originated from a voltage boost circuit. This device is configurable and can be operated in voltage boost mode or bypass mode. A MiniDySC can regulate 100% voltage and can provide it to the incoming AC line voltage. It can mitigate sags that are deeper up to 50%. The most common in all DySC is the static bypass switch will remain in turned ON position under all normal power conditions. This will allow the DySC to maintain a constant and efficient single-stage power throughout without any harmonics.

The static bypass switch will be turned OFF, and the IGBT inverter gets to begin the operation when the switch detects the difference in line to neutral voltage. The commutation of a thyristor is accelerated by the injection of voltage. The difference in desired and missing voltage is calculated, and that difference becomes the reference point for the IGBT inverter voltage regulator. The circuit can be modified to supply only the missing voltage to compensate for the voltage sags. The DySC takes less than 1/8 cycle to detect the voltage sag, accelerate the thyristor, and to begin the compensation.

Moreover, the DySC does not depend on stored energy to mitigate the missing voltage; it draws power from the input line whenever it finds the reduction in voltage magnitude to 50% or even less. The MiniDySC will have sufficient energy storage to compensate for 100% of missing voltage up to 3 cycles. By adding the additional capacitors can increase the ride through time up to 15 cycles.

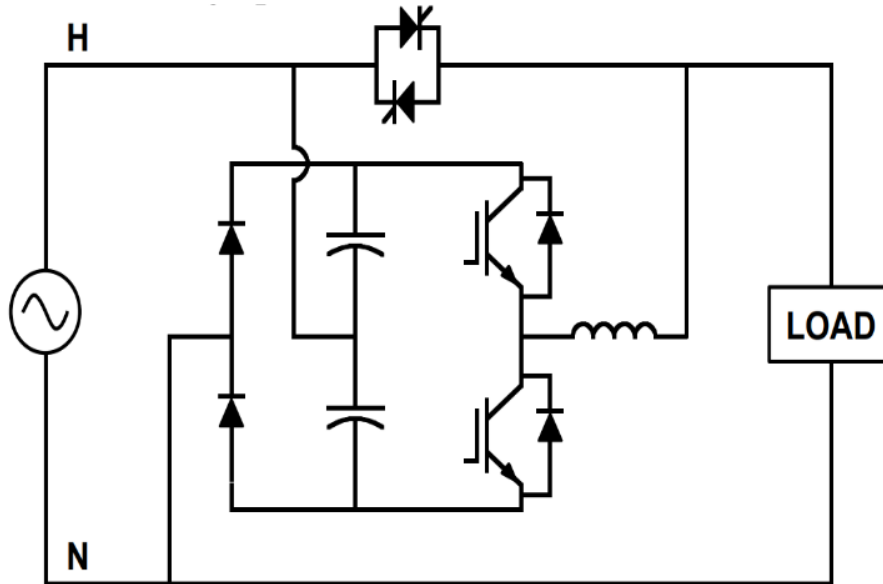

FIGURE 9: Mini Dynamic Sag Corrector [19].

5.2 Three-phase ProDySC and MegaDySC

The MiniDySC is applied to single-phase applications up to 500 kVA. From there it is realized that it can be adopted for three-phase applications up to 2000 kVA with a new product called ProDySC. It offers desired solutions when the device is connected to a series-coupled transformer mimicking the other available solutions in the market, like SSVR or DVR. These products work by inserting a transformer in series with the lines and injects the missing voltage to compensate sags. Most of the Dynamic sag correctors can mitigate sags until 50% of nominal

voltage drop but providing an external storage device can improve the ride through time for deeper voltage sags.

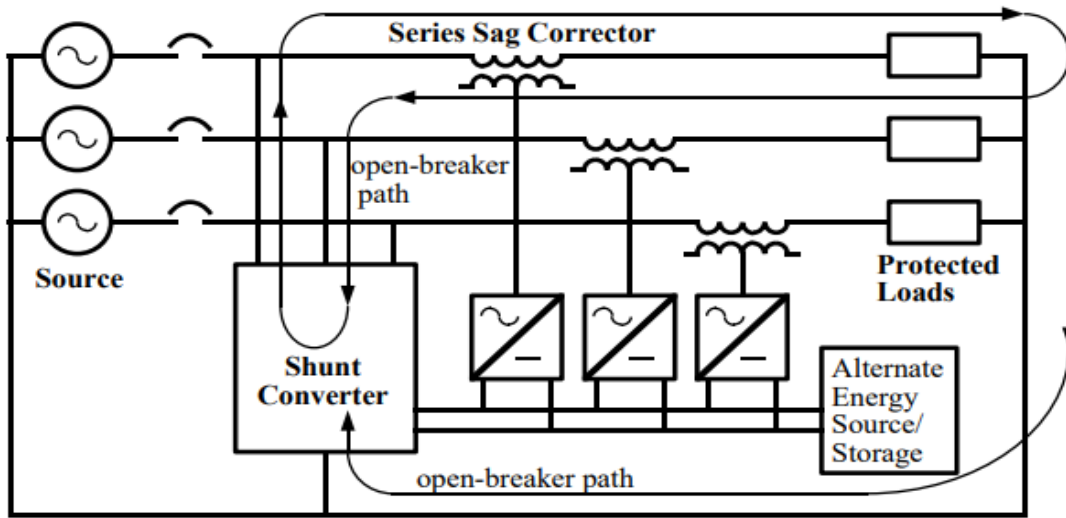

FIGURE 10: Series circuit provides a load current circulation path [19].

5.3 The MegaDySC

The applications for which they require ultra-clean and more reliable power from the utility, the only solution for this is to use external sources like UPS and generators. At the distribution level, the chances of the occurring voltage sags are low, but at the lower level, there might be more chances that they occur and create faults downstream but not affect any upstream breakers. However, the use of individual feeders or by using static transfer switches is not enough to mitigate or reduce the voltage sags or short time interruptions. This technique is very costly, and performance is not reached to the desired expectation. So, this technique is not widely accepted or adopted. Some authors recently proposed a new solution for this to improve the performance of MegaDySCs with a fast transfer vacuum switch to a dynamic sag corrector which would provide more reliable power to the system. This method can even offer a solution for the transmission level sags.

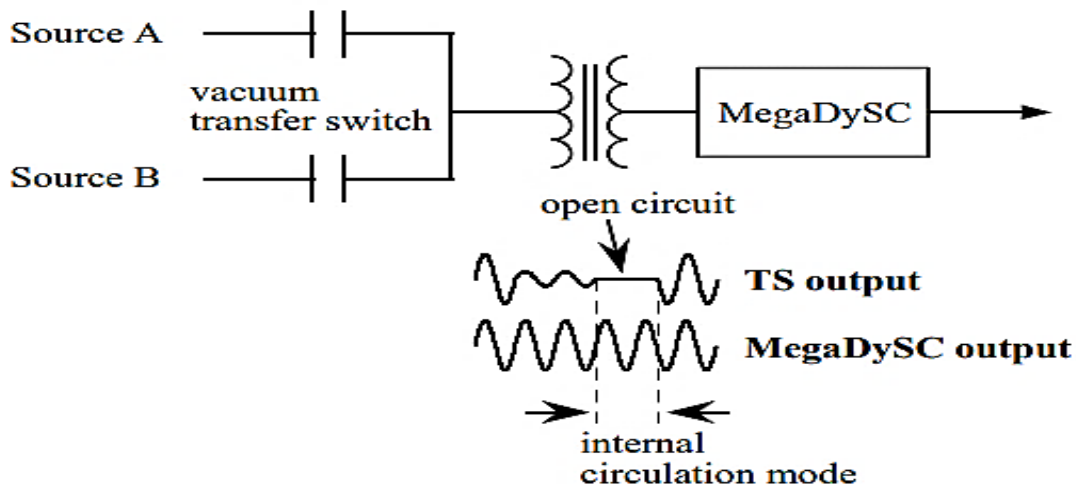

FIGURE 11: MegaDySC with a vacuum transfer switch [19].

6. SENSITIVE TOOLS

6.1 Power Supplies

Essentially a Power supply is a device that provides power to an electrical load. The main function of a power supply is to take electrical energy and convert it from one form to another form such as AC to DC or vice versa. In some cases, power supplies are even referred to as electric power converters. Depending on its design a power supply may obtain energy from different types of energy sources, including electrical energy transmission systems, batteries or solar cells, electromechanical systems such as generators and alternators, or another power supply.

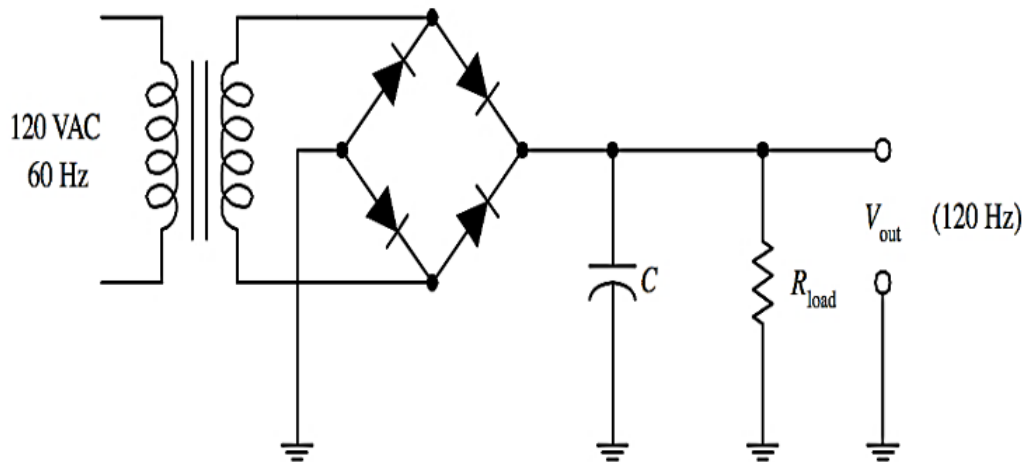

FIGURE 12: Simple AC to DC converter power supply [20].

The above-shown circuit is an AC to DC converter. In this 120VAC is converted to 24VDC. All power supplies have input, which receives energy from the source and output that delivers energy to the load. These power supplies play a major role in electronics, especially in the case of programmable logic controllers. PLCs need for power supply for their input and output racks. SEMI developed standards for power supplies to make the connected loads ride through voltage sags. The power supplies can act as power conditioners that protect the connected equipment by providing a continuous supply.

6.2 Contactors

These are one of the main sensitive devices to the voltage sags. Whenever a relay is used to switch high amounts of power through its contactors then it is characterized as a new device called Contactor. Contactors are used by electrical equipment which is frequently turned OFF and ON with the opening and closing of the circuit. The operation and function of a contactor are to turn ON and OFF all power supply lines running to a load or to repeatedly establish and interrupt an electrical power circuit. These contactors can be seen in control circuits and can act as a switch or a starter for motor control circuits. Typically, the contactor is operated with a lower-powered circuit as low as 24V can start a 230V motor. Contactors are classified into two types, IEC and NEMA. Contactors are differed by their speed, size, and operation time.

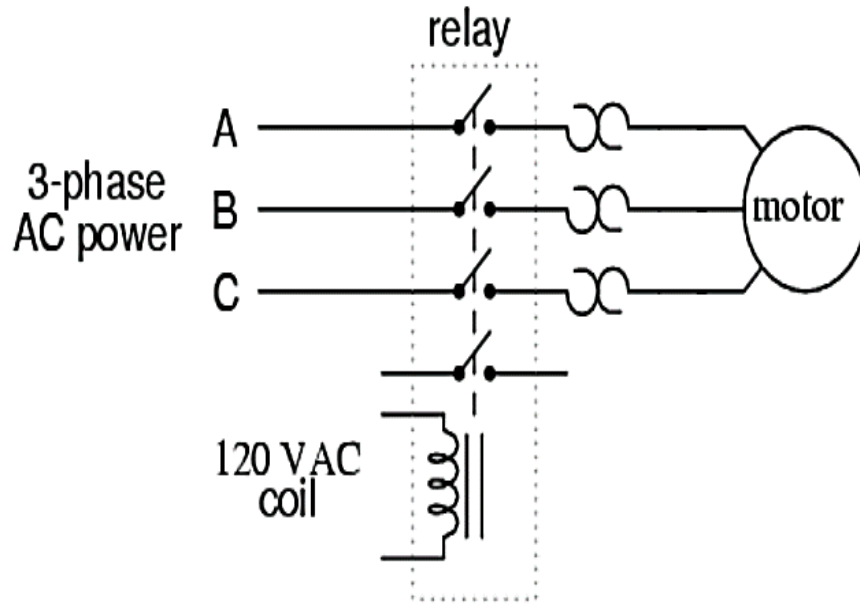

FIGURE 13: Contactor connected to a motor [21].

6.3 Relays

According to the IEEE standard dictionary, relays are kind of switches that will open and close electromechanically. These relays can control a circuit by opening or closing the contacts of another circuit. Commonly in the relays, there is a closed contact when the relay is not energized. Even if the relay has open contact, then it is possible that it is not energized. In both cases applying the electrical current can change their states of contacts.

These relays are normally used to start the smaller currents in a control circuit. So, in a simple way relays can even start or control the motors which consume larger voltages or currents. In some cases, protective relays can even protect the circuits from overcurrent or under current situations by detecting the voltage difference. There are two types of relays; one is Electromagnetic Relays (EMR) and Solid-State Relays (SSR). The main difference between these two relays is the requirement of the electrical load, cost, and reliability. Nowadays the solid-state relays have become more popular and are widely used than electromagnetic relays.

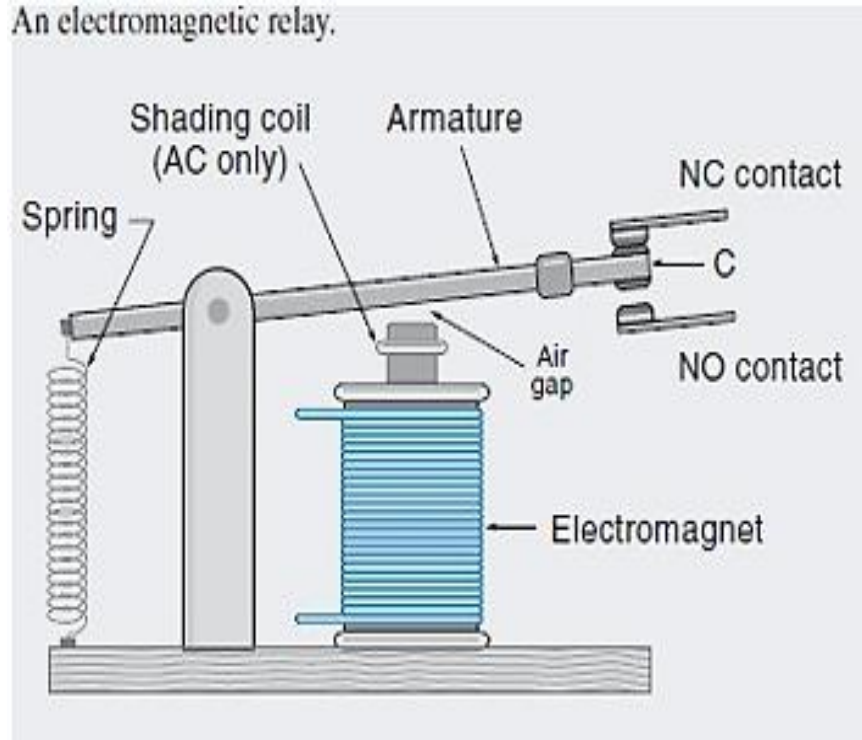

FIGURE 14: Electromagnetic Relay (EMR) [22].

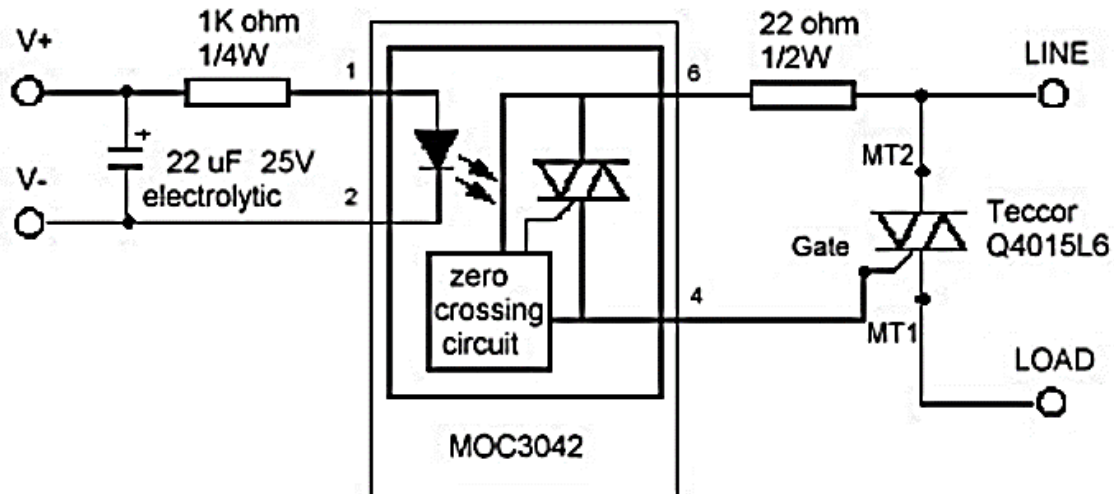

FIGURE 15: Solid State Relay (SSR) [22].

6.4 Variable Frequency Drives

The use of variable frequency drives has been increased in all HVAC applications. These are commonly used in chillers, compressors, pumps, and air handlers. A VFD uses power electronic devices to control the frequency of input power to the motor. This helps in controlling the speed of the motor. A VFD consists of mainly three sections which are, rectifier, DC bus, and inverter. A rectifier typically converts the AC voltage into DC voltage by allowing positive and negative voltage to each diode. After the voltage is converted, it is stored on a DC bus. This DC bus is loaded with capacitors to store the DC voltage. Then from the DC bus, the voltage is supplied to

the inverter. The inverter contains transistors that can switch ON and OFF several times in a second. This makes a VFD to supply power precisely to the motor. IGBT transistors are mostly used nowadays in VFDs.

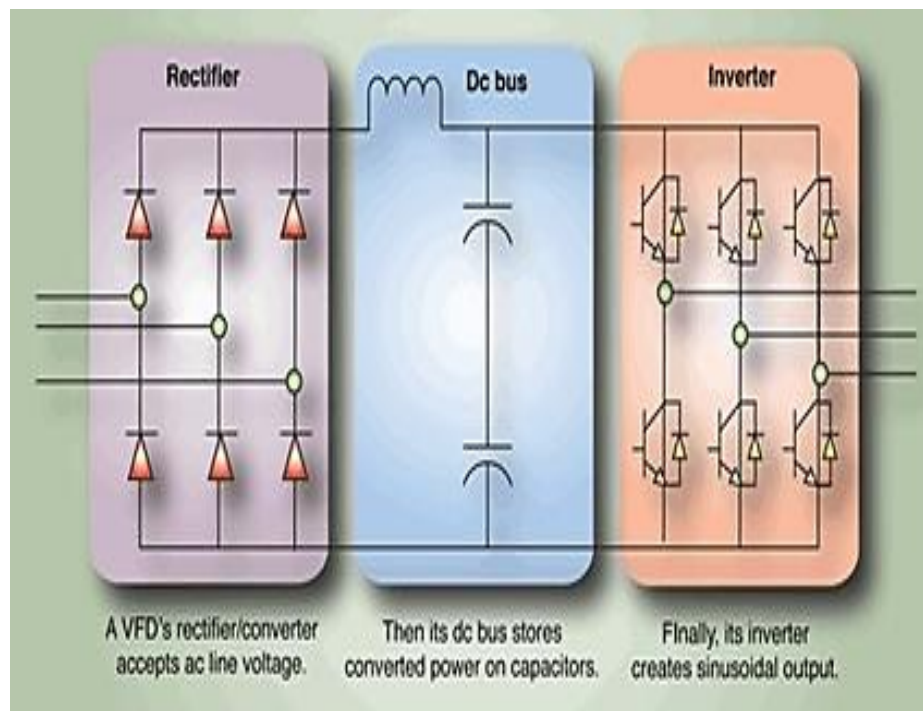

FIGURE 16: Structure of VFD [22].

These variable frequency drives are very sensitive to voltage sags. Variable frequency drives need continuous power to maintain the sinusoidal waveform and can supply continuous power to motors which can be operating the compressors, chillers, and air handlers. Improving the VFD's performance will be discussed in later sections of this report.

7. PROPOSED METHODOLOGY

Fundamental control components are used in every type of equipment; a basic understanding of their response to voltage sags can help designers build and service a more reliable process machine. Basic control components include, but are not limited to Relays, AC Contactors (Motor Control Relays (MCR) and Starters), DC Power Supplies, Controllers (PLC), Adjustable speed drives (AC and DC). These components need to be made more robust to help them ride through voltage sags. The industrial plant was observed and carefully studied and the sag events on the substations were reviewed. The following modifications were proposed and implemented in sensitive devices such as power supplies, relays, contactors, and variable frequency drives to improve the voltage sag immunity for these susceptible tools.

7.1 New Equipment Design

Equipment specifications must meet SEMI F47 and other equal standards. As mentioned in section 1.2. SEMI has developed the voltage sag standards and has put effort to set the voltage sag standards. Therefore, each equipment or tool specification should be modified according to the requirement of the industry considering these SEMI F47 standards.

7.1.1 Design of Control Circuits and Its Components with DC Power

DC power supplies have a "built-in" tolerance to voltage sags because of ripple-correction capacitors inside as AC power supplies do not have the tolerance to voltage sags since they do not have inherent energy stored in them. When SEMI standards are used the circuit becomes

more tolerant. There are many types of DC power supplies available which are SEMI F47 compliant in that some of them are Siemens SITOP PSU8200 and PULS DC power supply. Changing the control circuit input from AC to DC can improve the immunity of the system. When coupled with DC I/O on the system, power conditioning is rarely needed. The tolerance of DC Power Supplies is dependent on the topology and load. Switch-Mode DC supplies are more tolerant than unregulated supplies. DC supplies lightly loaded will be more tolerant than heavily loaded supplies.

The EMO circuit is typically more vulnerable to voltage sags. According to the tests conducted by SEMI, 47% of the time EMO circuit tripped because of the main contactor and EMO relay. These contactor and EMO relay specifications need to be changed to improve the voltage sag ride-through immunity for the circuit. Whenever the sag occurs the components in the circuit, tend to trip when the voltage drops below the nominal voltage. This is mainly due to the weak components which are used in the circuit. So, when the voltage is dropped during the sag, it affects not only the normal circuit operation but also, the emergency of the circuit. These weak links need to be made more robust. DC power supplies and sag tolerant relays and contactors can help the circuit to ride through voltage sags.

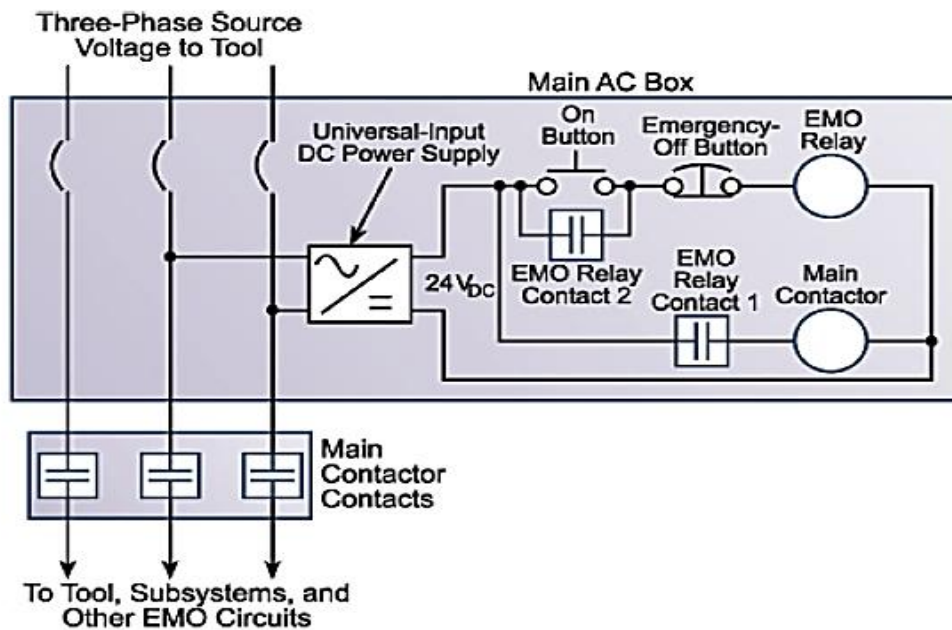

FIGURE 17: Emergency control circuit [23].

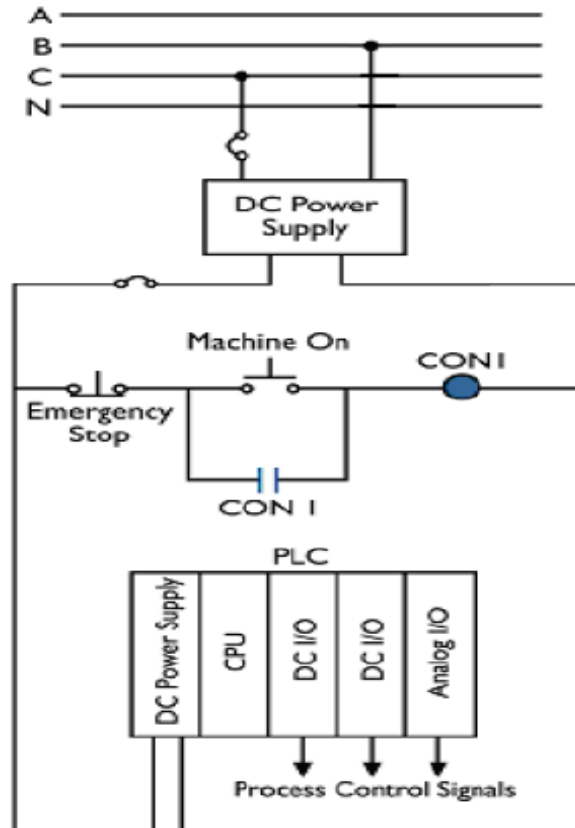

FIGURE 18: DC powered PLC circuit [23].

7.1.2 DC Power Supply Buffer Module

DC Buffer module is a device that is installed in parallel with the output of the DC power supply to offer extended time for voltage sag ride-through protection. There are many manufacturers of DC voltage buffer modules. Most manufacturers say that buffers can be used in parallel to supply more energy. These modules can supply power up to 15 seconds at full load current in the event of an interruption of DC power. Power failures usually last only for fractions of a second. However, they can cause time and cost-intensive damage to sensitive production areas. A reliable power supply is the basis for every manufacturing process, every plant and ensures reliable interruption-free operation. DC UPS modules offer protection against longer power failures. The maintenance-free DC UPS provides reliable 24 V with capacitors for up to several minutes, and by the DC UPS with battery modules for up to several hours. The advantages of the buffer module, it is easy and fast to connect the basic module to 2 lines for protection against short power failures. Buffering time 100ms to max.10s, depending on current load Multiplication possible using parallel switching The DC UPS bridges lengthy power failures.

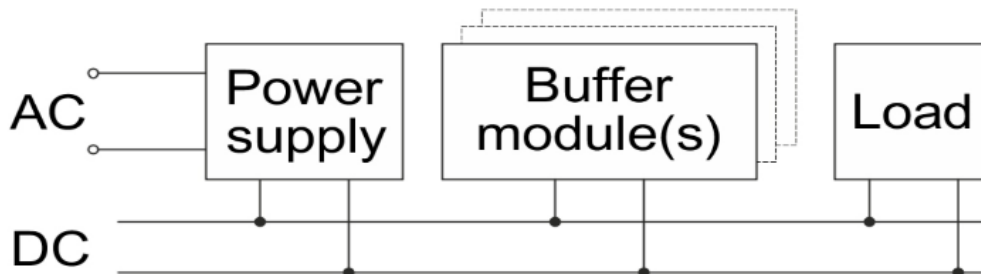

FIGURE 19: DC Operation of Buffer module [23].

7.1.3 Trip Curves for Circuit Breakers

Equipment with AC-DC converters can respond to voltage sags by drawing high inrush currents when the voltage supply returns to normal. During a Sag event, the capacitors in the AC-DC converters will discharge. At the end of the sag, the sudden presence of a full voltage causes the discharged capacitors to recharge rapidly. The magnitude of inrush currents depends on the depth and duration of the Voltage Sag. The resulting current transient may be large enough to trip the circuit breakers that have a quick response time. This voltage sag to 40% of the nominal voltage drop caused the capacitors in a variable-frequency drive to discharge. When the input voltage returned to normal after six cycles, the capacitors suddenly recharged, causing a high inrush current that peaked at 360% of the normal operating current. To avoid this, the power supply design must be modified to lower the DC bus under voltage trip point, and the circuit breaker should be modified without an instantaneous trip.

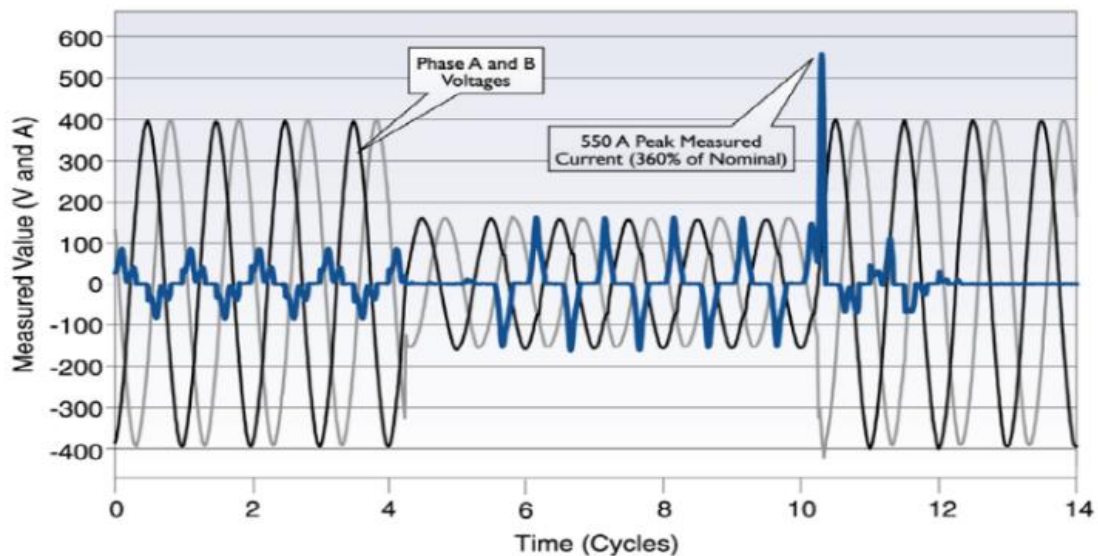

FIGURE 20: Sag recovery curve with high inrush currents [24].

7.2 Modifications in Existing Equipment

In general, for the existing equipment, these solutions involve fixing the individual “weak links” components of a tool to increase the overall ride-through of the entire system. Embedded solutions are attractive since they, in theory, do not require to add a power conditioning device, but instead involve using more robust or improved components in the tool design. So, the common weak links are relays, contactors, Variable Frequency Drives (VFD), and programmable controllers.

7.2.1 Modifications in AC Control Relays

If AC Relays used in the circuit design, then we need to use some sag tolerant components. AC relays and contactors can be made more robust by changing their specifications.

These specifications include an integrated module solution that, a voltage sag tolerant general-purpose DC DPDT relay allows for the quick, easy replacement of an existing AC DPDT sensitive 24Vac or 120Vac relay for retrofit or new applications.

This solution vastly improves the voltage sag ride-through characteristics of previously vulnerable electrical control system circuits like emergency off circuits (EMO) in semiconductor tools and modern production lines with no capacitance incorporated in the design. Therefore, with no time delay for dropout. So, these Nice Cube configured relays can go up to 30% of nominal voltage thus allowing more room for voltage sags.

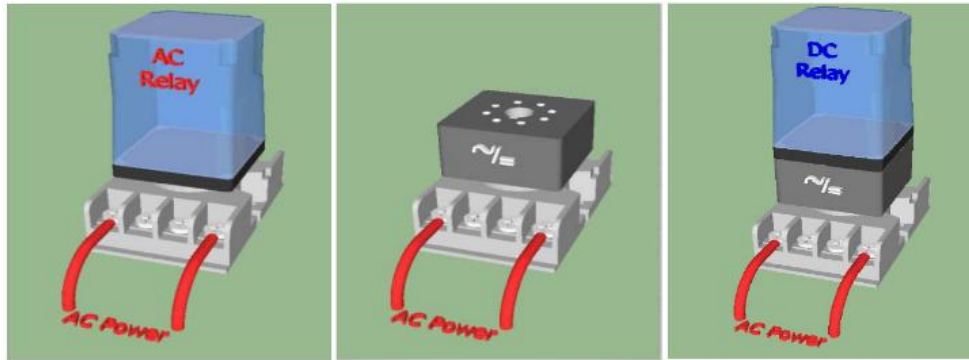

FIGURE 21: Configuration of Nice cube relays [25].

7.2.2 Modifications In Contactors

For the contactors, the low voltage ride through module developed by PQSI, these act as a coil lock hold in a device. This module is placed on top of the contactor which directly holds the copper contacts inside the contactor. This Coil-Lock is designed to make sure that any time if there is a voltage drop up to 25% in input voltage, the AC coil maintains enough energy to hold the critical contacts of the contactor. When there is a voltage drop of more than 25%, the coil lock releases the coil and turns the system off thereby ensuring safety. To properly apply the Coil-Locks to the contactor the best way is to determine the DC resistance of the AC coil of the contactor. Once we have the DC resistance of the AC coil of a contactor, we can select the appropriate model from the PQSI's coil lock devices.



FIGURE 22: Contactor with Coil-lock hold in the device [25].

7.2.3 Modifications In Programmable Logic Controllers (PLC)

PLCs are more susceptible to voltage sags. Voltage sags that occurred for at least a cycle can affect the PLCs, tending to the shutdown of control systems and causes loss of production time. Proper hardware and software integration can improve the response of the systems towards power disturbances. When addressing voltage sag-related problems, it is important to ensure that the PLC and the I/O control power are robust. Mitigation techniques like using power conditioners for the AC voltage circuits or installing a robust DC control power can provide effective mitigation. There is a need to select the best power conditioning devices to ensure the entire system must work efficiently. Some of the power conditioning devices that produce square-wave outputs are not compatible with all PLC systems. A three-phase AC supply is used as an input to the 24V DC output power supply. A small power conditioner is used if a PLC AC power supply is integrated into the module.

A more robust approach is to use a DC power rack supply and a robust DC power supply for the control, at 50% of nominal voltage PLC can still ride through even AC I/O starts to stop. Delay filters can be used to verify the presence of power and used as a “de-bounce” mechanism when the components in the circuit drop out due to voltage sag. A program is designed to detect the auxiliary contact is open for more than 250ms. If the contact is open for more than a preset time, then the “Timer on Delay Coil” in Rung 2 will be set and unlatch the previous rung to eliminate voltage from the motor starter.

7.2.4 Drive Configuration Settings

VFDs are more important for an integral part of the equipment in many continuous processes and other applications. Because of the wide usage of VFDs in the process industry, the momentary voltage sags have a large impact on production equipment operation, and this has become a big problem for the end-users. The total industrial plant production will stop due to the tripping of VFDs, which results in financial losses with downtime, loss of the equipment, and even in some cases damage to the product. The effect of sag depends on available fault current, system impedance, and distance from the fault. In most scenarios, the magnitude of the sag is about 60 to 70% of the nominal voltage drop. So, there is a need to protect these VFDs from not tripping during the momentary voltage sags. The manufacturers do not enable some of the parameters in the VFDs. But these parameters can be changed to help VFDs to ride through voltage sags. There are different kinds of options available in VFDs such as automatic restart, catch a spinning load, and the current, torque limits can set a drive to tolerate voltage sag.

AC Drive Parameters that could improve ride-through are:

- a. Automatic Reset and Restart Functions.
- b. Motor- Load Control Functions (Flying Restart).
- c. Acceleration /Deceleration / Current / Torque – Limits.
- d. Phase-Loss and DC Bus Under voltage Functions.

7.2.5 Installation of Dynamic Sag Corrector

After the case study of the industrial plant, it is discovered that the central utility building has more critical loads than any other sections of the plant. This building contains all the central compressor units and air handling units. Some of them are high pressure compressed air, low pressure compressed air, and reverse osmosis skids. These systems supply the entire plant. This equipment is run 24/7 to maintain the building. Even a one-hour downtime may cause a loss of thousands of dollars and therefore is a critical need to protect this equipment.

The High-Pressure Compressed Air (HPCA), Low-Pressure Compressed Air (LPCA), and Reverse Osmosis skid (RO) are considered as the main base for this research and install the MiniDySC. Some other systems have also connected with MiniDySC. On the HPCA the control voltage is 120Vac through a 4160V/120V, 1kVA transformer. MiniDySC has been installed on the secondary side of the transformer to protect sensitive tools. For the LPCA and RO skid, the control voltage is 120Vac through an individual 480V/120V, 1kVA transformer. These units have two central units that have different control circuits.

So, each of them requires a MiniDySC to compensate for the missing voltage during the voltage sag event. These MiniDySCs are of 120V and 12A to 25A depending upon the system requirement. HPCA, LPCA, and RO skid have individual motor control panels in which they have the control circuit to start the compressors. These Motor control panels are C1-ACP-211-003: LPCA 3, C1-ACP-212-003: HPCA 3, C1-ACP-211-001: RO skid. The below-shown wiring diagrams of the individual system are provided by the vendor.

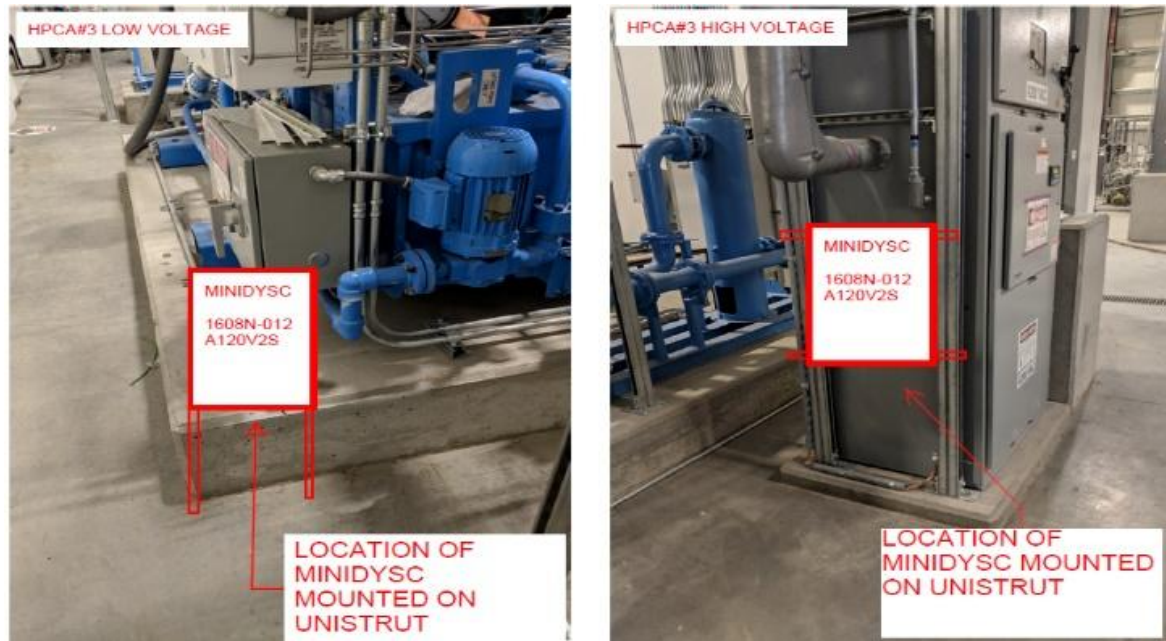

FIGURE 23: Site location of MiniDySC installation for HPCA.

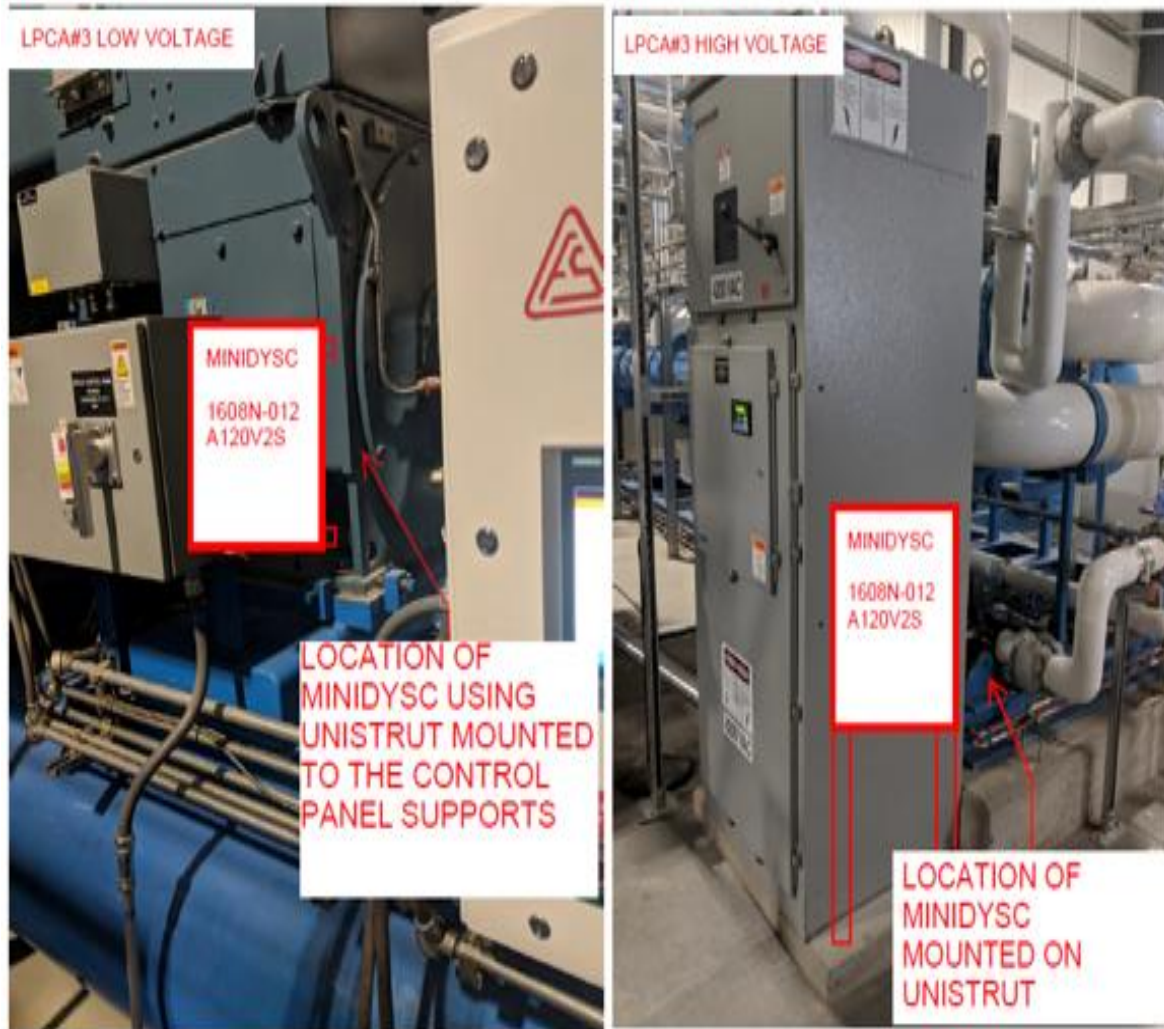

FIGURE 24: Site location of MiniDySC installation for LPCA.

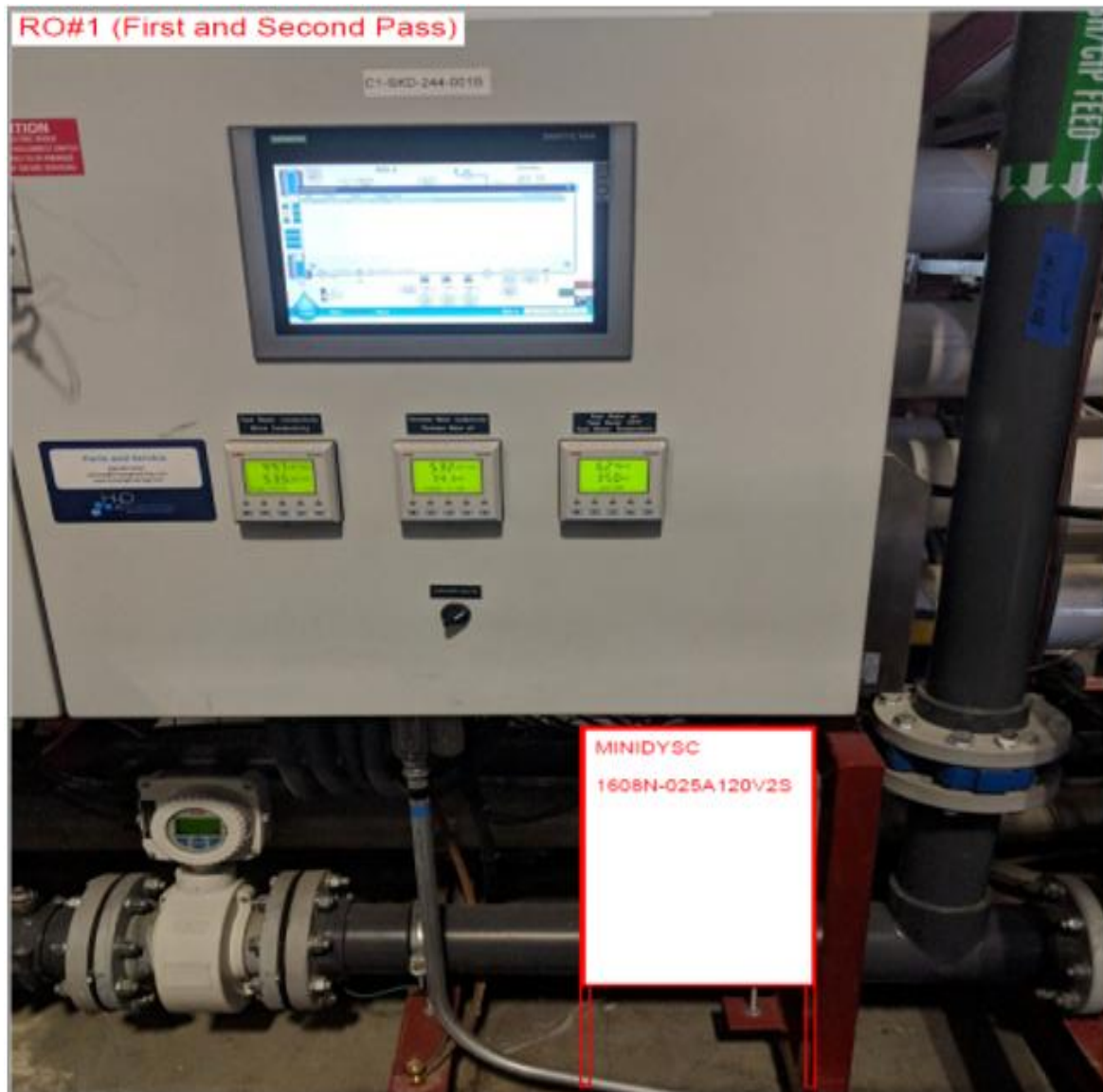

FIGURE 25: Site location of MiniDySC installation for RO skid.

8. IMPLEMENTATION AND RESULTS

After studying the industrial plant and understanding the sag events on the substations, modifications proposed above were applied in sensitive devices such as power supplies, relays, contactors, and variable frequency drives to improve the voltage sag immunity for these susceptible tools.

8.1 Relays and Contactors

As proposed in the earlier sections, the Ice cube relays get replaced with Nice cube relays. These Nice cube relays are very useful to voltage sags and can protect the equipment even if the voltage drops to 30%. If the control circuit is AC then, PQSI 120Vac Nice cube relays can be used. If the control circuit has the DC power then, 24Vdc nice cube relays can be replaced with ice cube relays. As the industrial plant is enormous and the machines run continuously, it is not possible to shut down the systems at the same time to make these proposed changes. It takes time to apply these modifications to each of the individual control circuits as they need to be shut down at a particular time when they are not in usage. Sample results and equipment

specifications are shown below as they accurately represent the results of industrial applications. The graph below is the comparison between the Ice cube and Nice cube configured relays. AC Ice cube relays will tolerate the sags only up to 75%, whereas the DC Ice cube relays can tolerate sags up to 58%. When both AC and DC Ice cube relays are compared to the AC and DC Nice cube configured relays, nice cube relays are far better in operation during voltage sag events. These Nice cube relays can go up to 25% of voltage drop. So, these relays will be installed in each control circuit to avoid the tripping of the circuit.

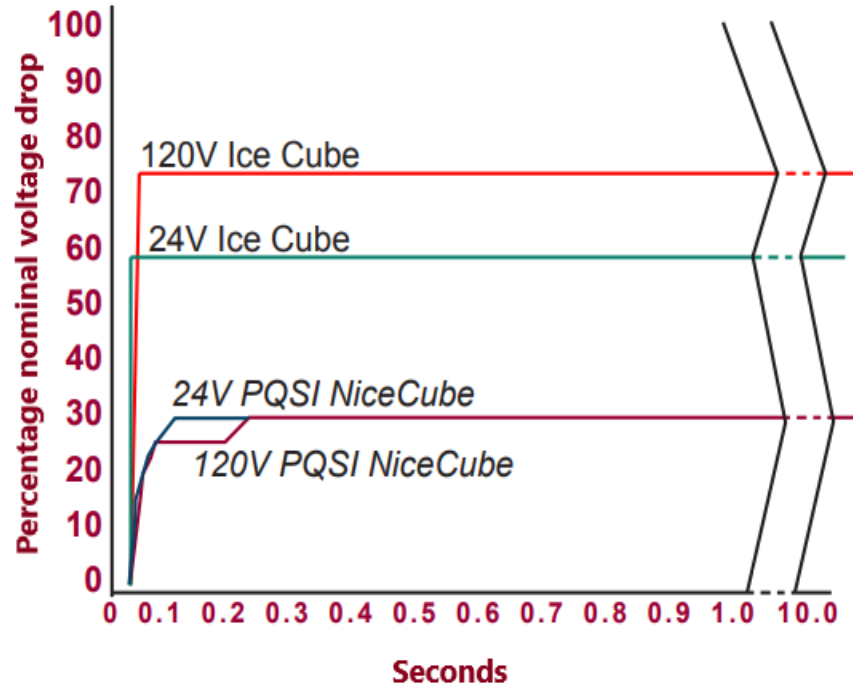

Figure 26: Nice cube relay voltage sag ride-through curves [26].

When it comes to Contactors, these can ride through voltage sags until the voltage drops to 20% of nominal voltage with coil-hold in a device installed on it. These get installed in every control circuit of individual systems. The coil-hold in the device de-energizes when the voltage drops more than 20% nominal voltage and helps in the safe functioning of emergency off circuits.

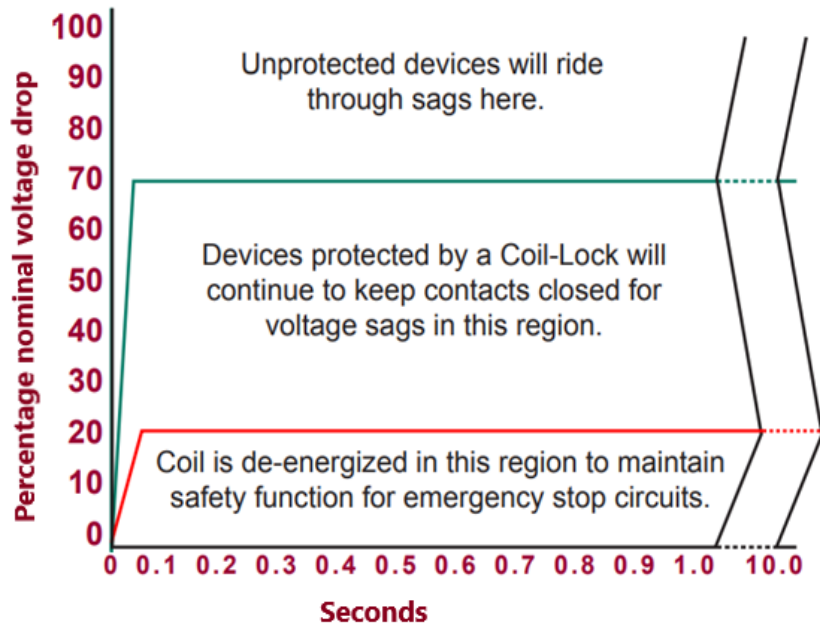

Figure 27: Voltage sag ride through curves for contactors [27].

8.2 Variable Frequency Drives

Variable frequency drives play a vital role in all the compressors. HPCA, LPCA, and RO skid have these VFDs which protect the motors running the compressors. All these VFDs need to be SEMI F47 compliant to protect the motors from damage during the voltage sag events. The Siemens VFDs which are running the motors of HPCA and LPCA are not SEMI F47 compliant. But the Schneider's VFDs running RO skid are SEMI F47 compliant. The Siemens variable frequency drives need to be modified with parameter changes to make them tolerate voltage sags. The following parameters have changed in these non-SEMI compliant VFDs. These parameter changes in these drives ensure continuous operations during the voltage sag events. But unfortunately, we cannot monitor the sag events on these VFDs. The only way we can control by installing an additional power monitoring device on top of it.

Parameters	Description	Recommended Value	Value description
P1200	Flying Restart	4	Flying restart always active (start only in set point direction)
P1210	Auto Restart	4	Restart after line supply failure w/o additional start attempts
P1211	Auto restart attempts	3	
P1212	Auto restart delay time	1 sec	
P1213	Auto restart monitoring time	60 sec	

TABLE 3: Parameter changes in variable frequency drives.

The other kind of VFDs is SEMI F47 compliant which is running RO skid. These VFDs have the built-in parameters that are automatically set to the default values by the manufacturer to make them ride through voltage sags, and these values can be changed depending upon the application. So, for the RO skid, the parameters have been adjusted accordingly to make the VFDs more tolerable to voltage sags.

Parameter	Settings
Input phase loss	Ignore
Catch a spinning load	Yes
UV Timeout	3 Sec
Dynamic Torque	High Torque A

TABLE 4: Parameter settings for SEMI F47 compliant VFDs.

8.3 Mini Dynamic Sag Corrector

As proposed in section VI. e, the Mini dynamic sag correctors installed on all these three systems HPCA-3, LPCA-3, and RO skid. Other systems are also installed with MiniDySC, but they are not included in this research but are shown in the installed list. HPCA-3 and LPCA-3 have three control circuits. One for the motor starter, another for compressor control, and the last is for Air dryer. RO skid has only one control circuit for the reverse osmosis process.



FIGURE 28: MiniDySC installation on HPCA-3.



FIGURE 29: MiniDySC installation on LPCA-3.

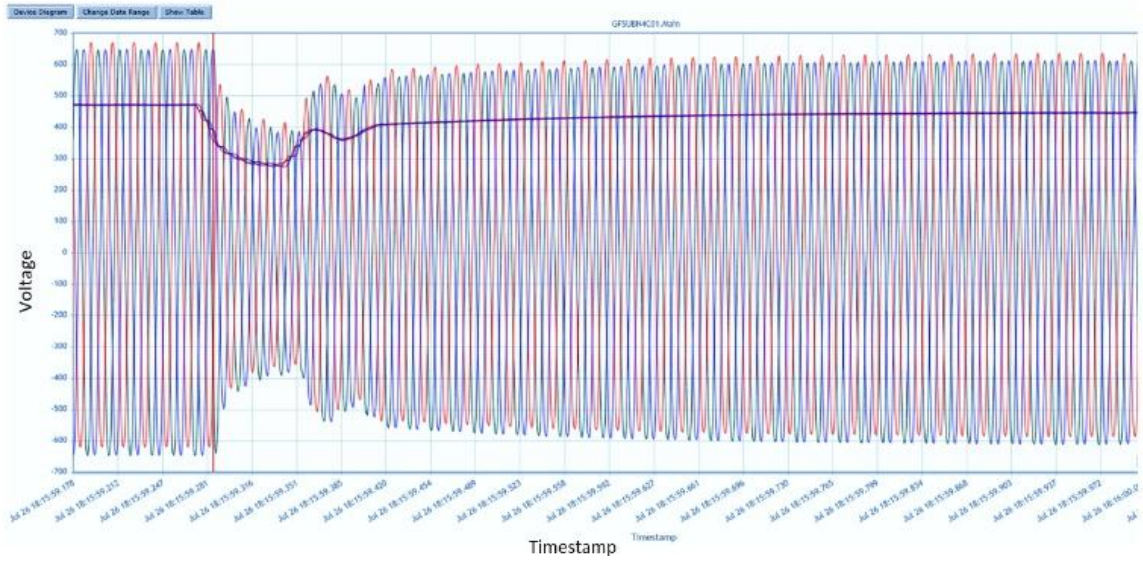

FIGURE 30: MiniDySC installation on RO skid.

8.4 Sag Events and System Ride Through Curves

The industrial plant experiences on average 10 to 15 voltage sag events per year. The worst sag experienced was about 49% on the Mira-Loma substation due to heavy winds. So, in these cases, all the systems were not able to ride through the voltage sag. This voltage sag affected HPCA, LPCA, and RO skid along with some other systems. The sag occurred on 7/26/2018 with a magnitude of 52% nominal voltage drop up to 29 cycles on all three phases in the time frame 18:15:59:281 and fully recovered at 18:15:59:441. So, this event caused the equipment to stop operating for 15 minutes. At the time the sag started, all equipment gradually stopped working one after the other. These sag events are monitored by power monitors placed on top of the substations. All the sag events recorded are seen in the Schneider electric power monitoring expert software.

The tools which have been affected through this voltage sag are HPCA, LPCA, and RO skid. Also, some of the other chillers have been affected. For instance, only three equipment results are shown. The figure shows the motor starter current waveform for all this three equipment.



... Expanded view of the above figure at the initial stages is:

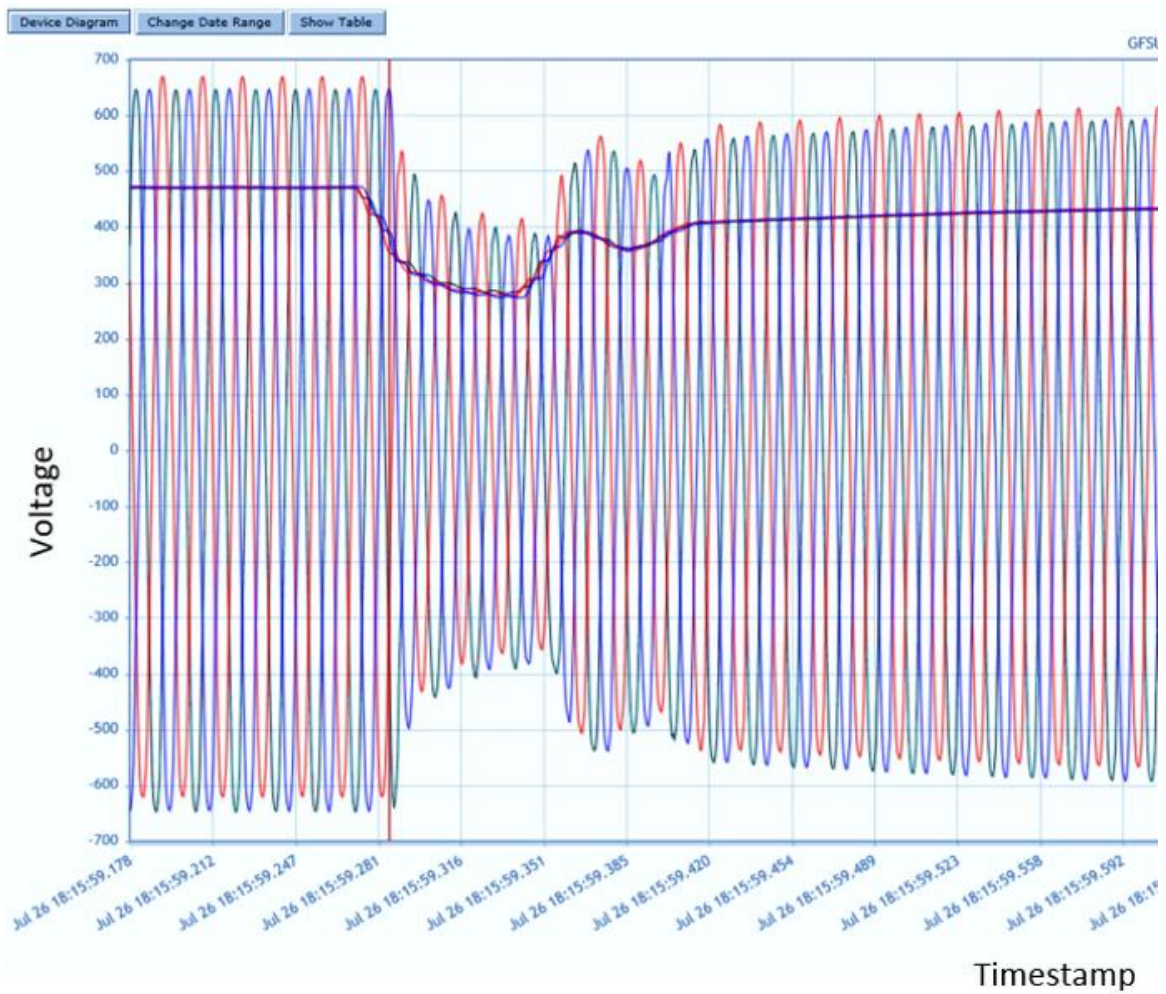
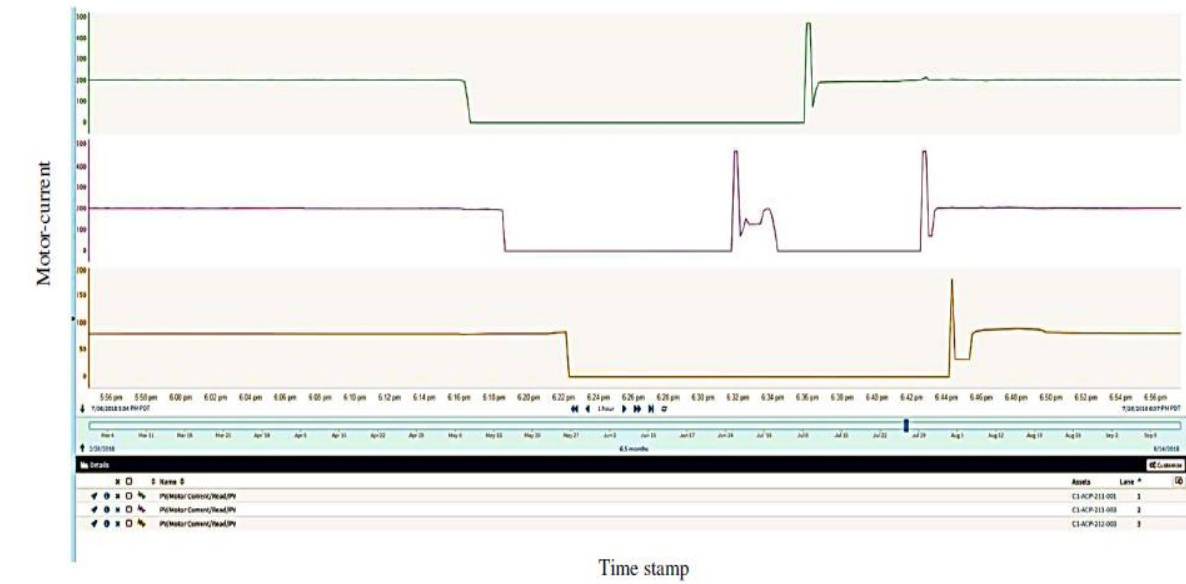

FIGURE 31: Recorded Voltage sag event waveform on 7/26/2018.



... Expanded view of the above figure at the initial stages is:

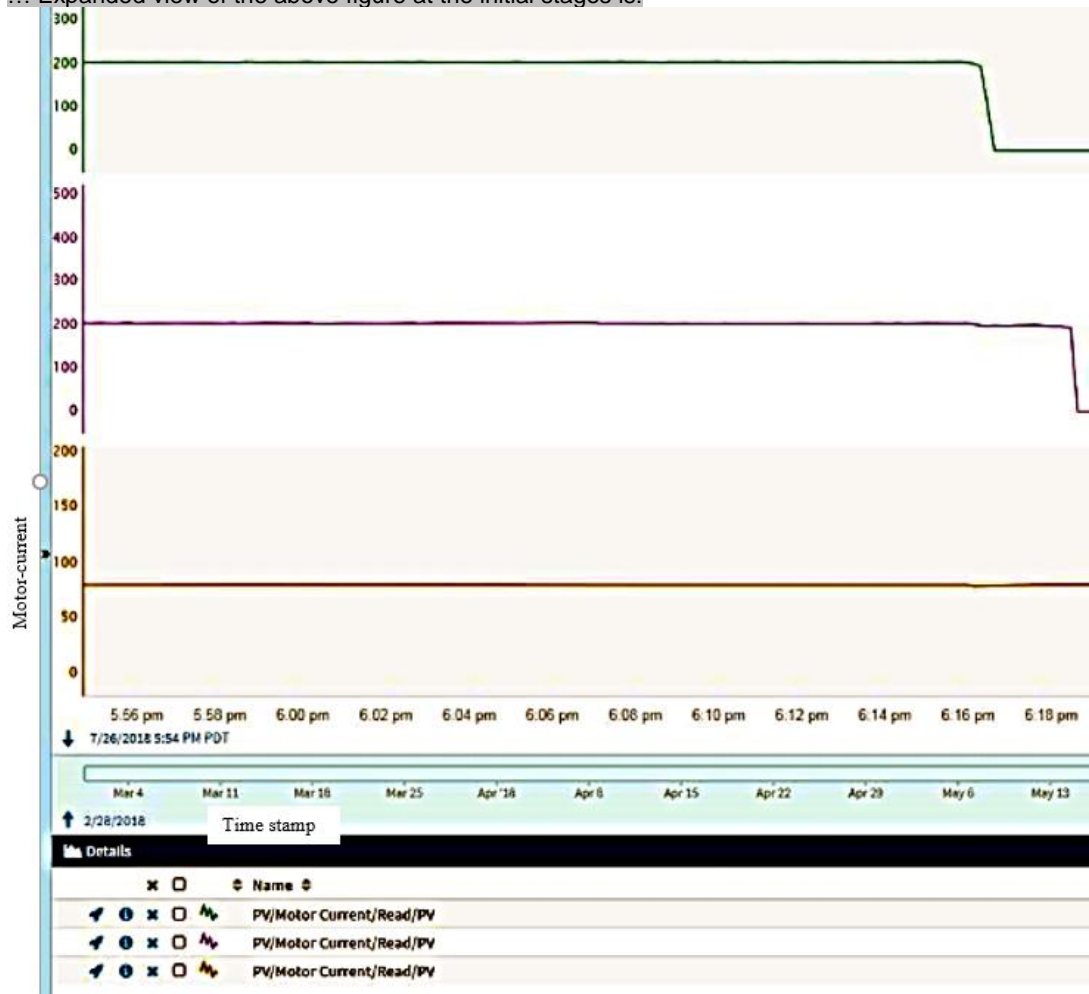
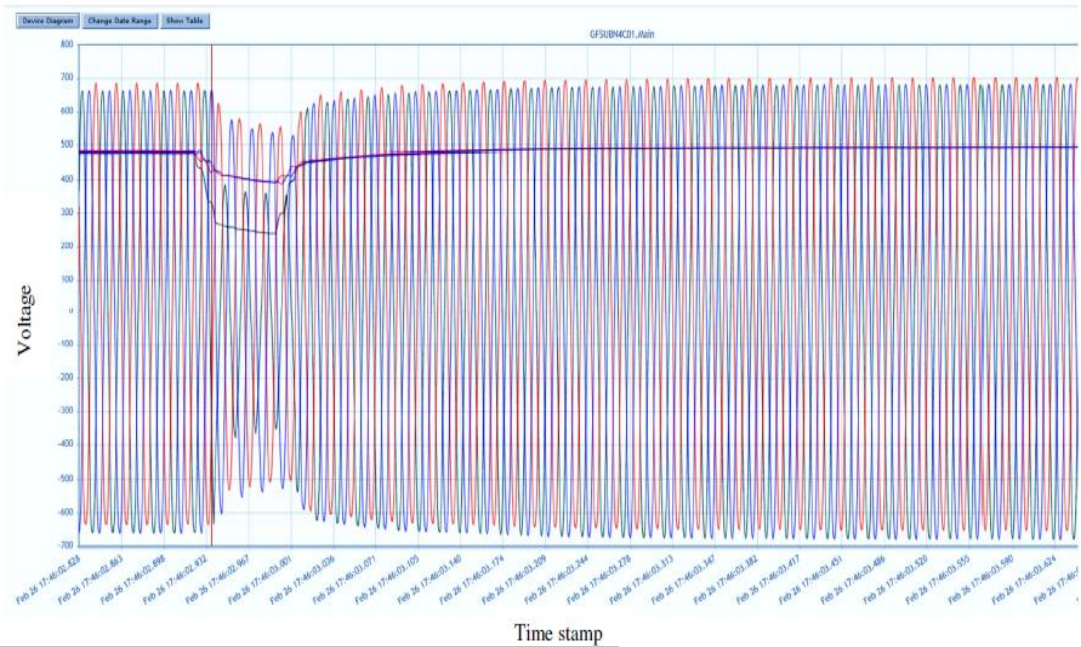

FIGURE 32: Waveform of affected equipment during the voltage sag event.

During this sag event, all three equipment were affected because the tools did not have voltage sag immunity standards, and they were not SEMI F47 compliant. This equipment was feeding only from a 34.5kV substation, and there were no power conditioners installed on them. All the precautions listed in the earlier chapters were taken to protect this equipment from further voltage sags.

There was another voltage sag event that occurred very recently on 02/26/2019. So far this was the worst sag that occurred in 2019 which was from 17:46:02:566 and the duration was 0.083000s. The voltage sag magnitude was worst as it went down to 49% of the nominal voltage on one of the phases. All equipment was able to ride through this worst voltage sag because of the installation of Mini Dynamic Sag Correctors on them.



... Expanded view of the above figure at the initial stages is:

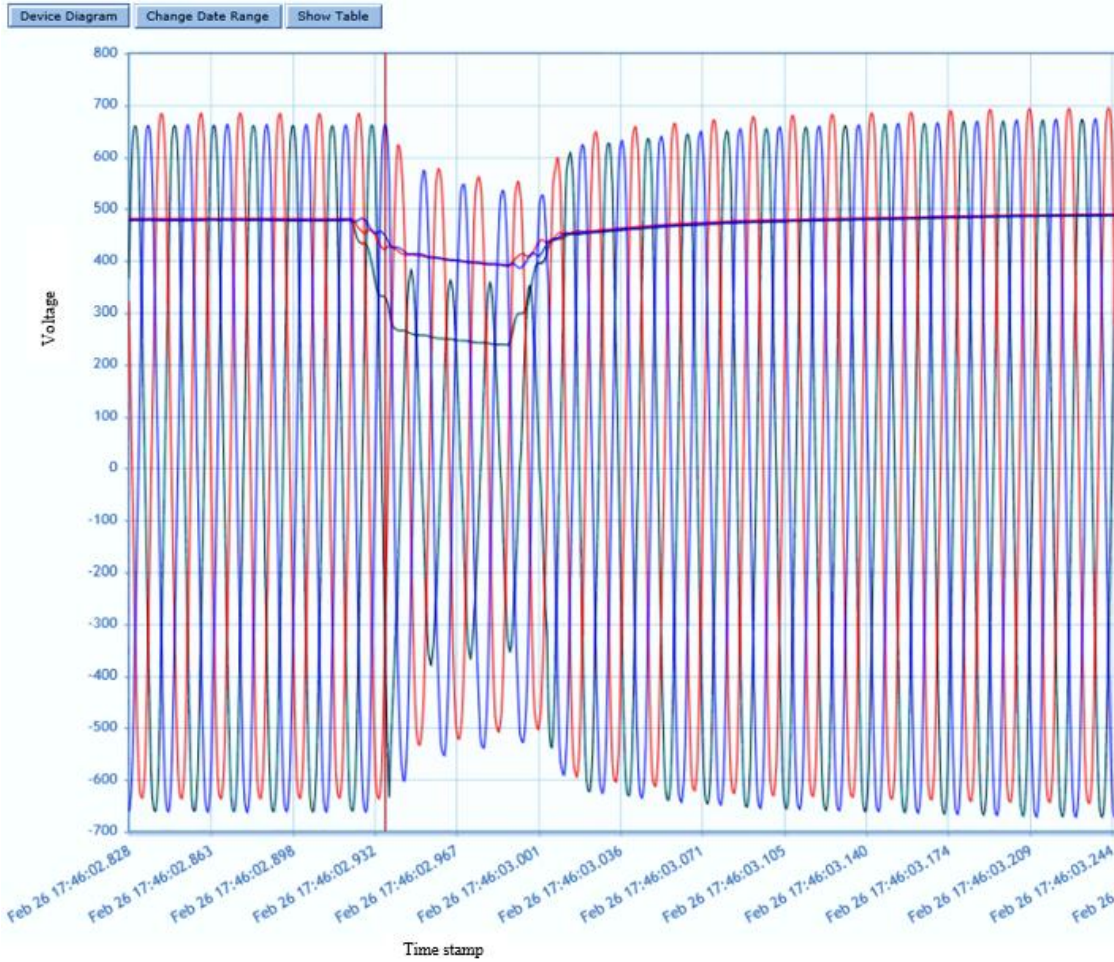

FIGURE 33: Recorded voltage sag event waveform on 02/26/2019.

The same tools which have been affected on 07/26/2018 due to voltage sag were not affected during this recent sag event. The waveform shown below illustrates that there was a continuous operation during the sag event. None of the equipment failed due to the MiniDySCs.



... Expanded view of the above figure at the initial stages is:

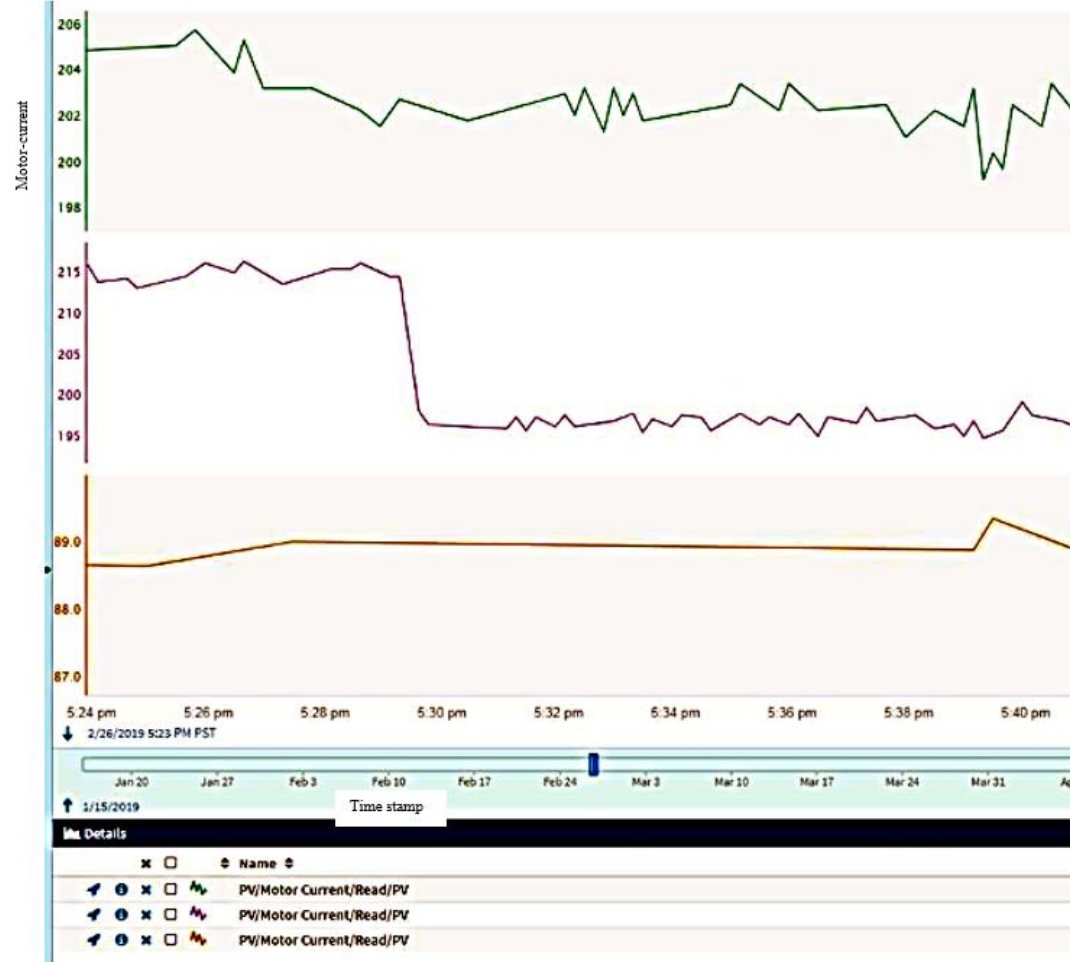

FIGURE 34: Equipment ride through curves during a voltage sag event.

9. ECONOMIC ASPECTS OF DYNAMIC SAG CORRECTOR

A Mini Dynamic Sag Corrector is a tiny device 22" x 10" x 4" which can easily fit into any system with no additional space required. The MiniDySC goes from 10A to 25A with a single-phase 120V, and the cost depends upon its amperage which goes from \$1500 to \$2200. These are very cost-effective devices for process equipment protection to voltage sags. The industrial plant required 20 MiniDySCs to protect equipment mentioned for a price of less than \$30,000. Instead of choosing the Dynamic sag correctors, if UPS were installed in a plant to protect the entire plant from the voltage sags, it would have cost 5 million dollars. This control level mitigation technique has saved a lot of money for the plant.

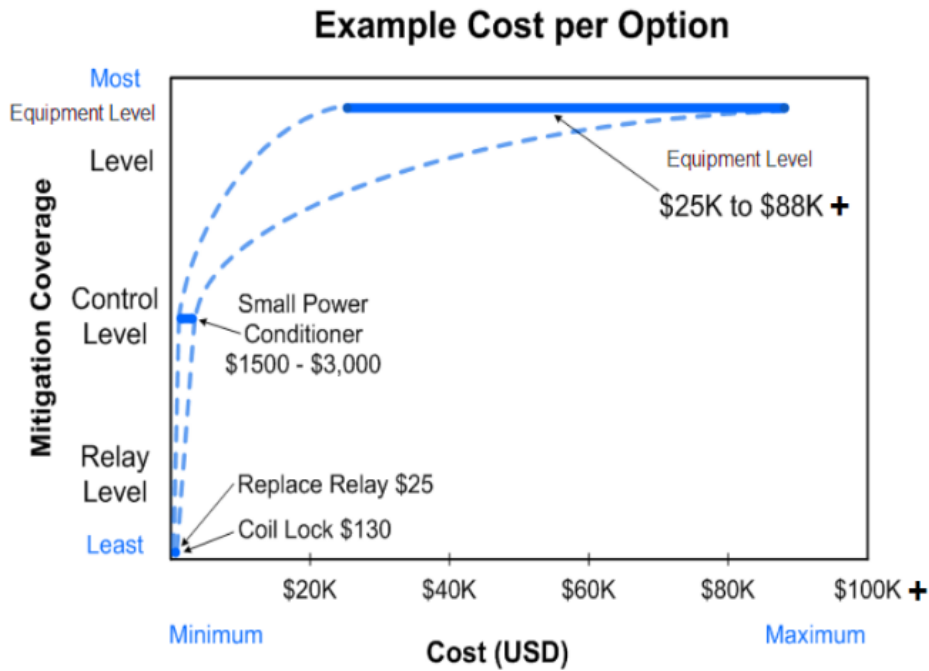

FIGURE 35: Cost analysis for different levels of mitigation techniques [28].

Equipment Name	Power Conditioning Voltage	Power Conditioning Product	Power Conditioning Price per Unit
HPCA #1 and #2	120V	1608P-025A480V3S	\$2,191.55
LPCA#1, #2, #3 - HV Section	120V	1608N-012A120V2S	\$1,972.56
LPCA#1, #2, #3 - LV Section	120V	1608N-012A120V2S	\$1,972.56
Air Dyers #1, #2, #3	120V	1608N-012A120V2S	\$1,972.56
HPCA#3 - HV Section	120V	1608N-012A120V2S	\$1,972.56
HPCA#3 - LV Section	120V	1608N-012A120V2S	\$1,972.56
RO Pass 1 and 2	120V	1608N-025A120V2S	\$2,191.55
nMP Refining Tower #1 and #2	120V	1608N-025A120V2S	\$2,191.55
NR-BLR-302-201 and 202	120V	1608N-012A120V2S	\$1,972.56
Steam Compressor #1 and #2	240V	1608N-025A240V1S	\$2,191.55
McKenna Skid	120V	1608N-025A120V2S	\$2,191.55
MT Chiller 1-3	120V	1608N-012A120V2S	\$1,972.56
MT Chiller 4-6	120V	1608N-012A120V2S	\$1,972.56
HRC	120V	1608N-012A120V2S	\$1,972.56
LTC	120V	1608N-012A120V2S	\$1,972.56

TABLE 5: Per unit cost of MiniDySC.

The table above indicates the per-unit price of each MiniDySC and the location of installation with a part number. The vendor from Allen Bradley provides the cost and part number.

10. CONCLUSION AND FUTURE WORK

The demand for the quality of power has increased in the power sector, and it has become a prominent issue. Thus, there is a need to solve problems affecting power quality. Among all the power quality problems, voltage sags are the most common power quality problems which cause the momentary losses of power in the systems which tend to damage the equipment. In all the mitigation techniques available in the market, the control level mitigation technique is the most cost-effective solution for voltage sags mitigation. In this research, the available mitigation techniques are presented. But the control level mitigation technique has been highlighted. This research focused on mitigating voltage sags at the control level through a cost-effective method using mini dynamic sag corrector at low voltage systems and proposed control level embedded solutions for equipment design and modified the technical aspects of electrical devices to facilitate the control circuit to ride-through voltage sags.

At the control level, the Mini Dynamic Sag Correctors are most effective in compensating for the missing voltage in the lines during a voltage event. The IGBT transistors inside the dynamic sag corrector are very fast in switching thus allowing in transmitting the required regulated voltage to the system. These devices can even protect the equipment from transients and momentary interruptions. It has been shown from this research work that it is possible to mitigate voltage sags at the control level by modifying the specifications of the process equipment such as relays, contactors, programmable controllers, and variable frequency drives.

For each piece of equipment, we can improve the ride through immunity by making the proposed changes, and for relays instead of using ice cube type, we can configure them to the Nice cube which enhances the robustness of the relay. For the contactor, we can use a coil-lock hold in the device which can hold the contactor by not tripping during the event of voltage sag. For the programmable controllers, we can use the DC power supplies to power the input rack which helps in providing uninterrupted supply and can also perform state machine programming to retrieve data that can be lost when the sag occurs. Delay filters can be used to remove the voltage from the main contactor if the contactor is open for more than the pre-set time thus allowing the plc to run in a healthy condition after the event of voltage sag. When it comes to variable frequency drives, these are very sensitive to voltage sags, and immunity standards can be improved by enabling some of the parameters like automatic restart and catch spinning load techniques which were being used in our research to make a VFD more robust to voltage sags. All the equipment needs to be certified by SEMI F47 and should meet the requirements of voltage sag immunity standards.

11. REFERENCES

- [1] M. H. Bollen. *Understanding Power Quality Problems: voltage sags and interruptions*, IEEE Press, New York, September 1999.
- [2] K.P.J. Macken, M.H. Bollen, and R.J.M. Belmans. *Mitigation of voltage dips through distributed generation systems*, IEEE Transactions on Industry Applications, 40 (6), November 2004.
- [3] D. Hucker. "Aircraft a.c. Electric system power quality," National Aerospace Electronics Conference, Dayton OH, USA, May 1970.
- [4] R.H. McFadden. "How does plant power distribution design affect today's machine tools?," Electrical Construction Design, October 1969.
- [5] S. Kamble and C. Thorat. *Characteristics Analysis of Voltage Sag in Distribution System using RMS Voltage Method*, ACEEE Int. J. on Electrical and Power Engineering, Vol. 03, No. 01, February 2012.

- [6] M. McGranaghan. "Effects of voltage sags in process industry applications," Stockholm PowerTech International Symposium on Electric Power Engineering, Stockholm, June 1995.
- [7] M. Stephens. "EPRI Power Quality Webinar," October 22, 2015. URL: <https://www.sceg.com/docs/librariesprovider5/pdfs/power-quality-webinar-10-22-15.pdf?sfvrsn=2> Last accessed [February 19, 2021].
- [8] M.M. Sankar, S.B.L. Seksena. *A cost-effective voltage sag compensator for distribution system*, International Journal of System Assurance Engineering and Management, Vol. 8, July 2015, pp. 56-64.
- [9] A.M. Saeed, S.H.E.A. Aleem, A.M. Ibrahim, M.E. Balci, E.E.A. El-Zahab. *Power conditioning using dynamic voltage restorers under different voltage sag types*, Journal of Advanced Research, Vol. 7, Issue 1, January 2016, pp. 95-103.
- [10] A.K. Kapse, C. M. Bobade. *Review of Voltage Sag Compensation Techniques*, International Journal of Advanced Research in Electrical, Electronics and Instrumentation Engineering, Vol. 5, Issue 4, April 2016
- [11] A.M. Eltamaly, Y. Sayed, A.H. Ahmed, A.N.A. Elghaffar. *Mitigation Voltage Sag Using DVR with Power Distribution Networks for Enhancing the Power System Quality*, International Journal of Electrical Engineering and Applied Sciences (IJEEAS), Vol. 1, No. 2, October 2018
- [12] A. Safdarian, M. Fotuhi-Firuzabad, M. Lehtonen. *A General Framework for Voltage Sag Performance Analysis of Distribution Networks*, Energies Journal, July 2019
- [13] C. Behera, A. Banik, A.K. Goswami. *A novel approach for voltage sag representation in a chemical industry: A case study*, wileyonlinelibrary.com/journal/eng2 , May 2020
- [14] A. Moghassemi, S. Padmanaban. *Dynamic Voltage Restorer (DVR): A Comprehensive Review of Topologies, Power Converters, Control Methods, and Modified Configurations*, Energies Journal, August 2020
- [15] M. Stephens, D. Johnson, J. Soward, and J. Ammenheuser. "Guide for the Design of Semiconductor Equipment to Meet Voltage Sag Immunity Standards," Technology Transfer # 99063760B-TR, International SEMATECH, December 1999.
- [16] "Voltage sag immunity standards by SEMI F47, EPRI, power quality" bulletin no.3, August 2007. URL: https://www.pge.com/includes/docs/pdfs/about/news/outagestatus/powerquality/power_quality_bulletin-issue_no.3-volt_sagimm_std-8-10-07.pdf Last accessed [February 19, 2021].
- [17] M. Johns and L. Morgan. "Voltage sag mitigation through ride-through coordination," IEEE annual textile fiber & film industry technical conference, May 1994.
- [18] A. V. Pandey and S. Shakil. *Power Quality enhancement & Sag mitigation using Dynamic Voltage Restorer*, Scientific and Engineering research, June 2013.
- [19] W.E. Brum Sickle, R.S. Schneider, G.A. Luck jiff and D.M. Divan. "Cost-Effective Industrial Power Line Conditioning," February 2001. URL: https://www.google.com/search?q=%5B19%5D%09W.E.+Brum+Sickle,+R.S.+Schneider,+G.A.+Luck+jif+and+D.M.+Divan.+%E2%80%9CCost-Effective+Industrial+Power+Line+Conditioning,%E2%80%9D+February+2001.&spell=1&sa=X&ved=2ahUKEwLr67xg_fuAhXEGc0KHYOXcNtYQBSgAegQIBhAv&biw=1071&bih=960 Last accessed [February 19, 2021].

- [20] J.B. Klaassens. *Series-resonant single-phase AC-DC power supply with control of reactive power*, IEEE Transactions on Power Electronics, February 1992.
- [21] M. Stephens. "Power Quality and Utilization guide PQ in Continuous Manufacturing," EPRI Solutions, January 2006.
- [22] Cigre Task Force C4.1.02, 2005. "Voltage Dip Evaluation and Prediction Tools," Draft November 2005.
- [23] A.N. St. John. "AROUND THE WORLD," IEEE San Diego Gas & Electric San Diego," Survey of recent Voltage Sag papers from CA, May 1993.
- [24] G.C. Paap. *Symmetrical components in the time domain and their application to power network calculations*, IEEE Transactions on Power Systems, May 2000.
- [25] PQSI, "Configurations for Coil-lock hold in devices," Power Quality Solutions Inc., November 2016.
- [26] D.L. Plette. "The effects of improved power quality on utilization equipment," IEEE National Aerospace Electronics Conference, May 1969.
- [27] D. Almeida. *Technical and economic considerations in the application of variable-speed drives with electric motor systems*, IEEE Transaction on industry applications, Vol 41, No 1, January/February 2005.
- [28] R.A. Eperly, F.L. Hoadley and R.W. Piefer. *Considerations when applying ASD's in continuous processes*, IEEE transactions on industry applications, April 1997.

INSTRUCTIONS TO CONTRIBUTORS

The *International Journal of Engineering (IJE)* is devoted in assimilating publications that document development and research results within the broad spectrum of subfields in the engineering sciences. The journal intends to disseminate knowledge in the various disciplines of the engineering field from theoretical, practical and analytical research to physical implications and theoretical or quantitative discussion intended for both academic and industrial progress.

Our intended audiences comprises of scientists, researchers, mathematicians, practicing engineers, among others working in Engineering and welcome them to exchange and share their expertise in their particular disciplines. We also encourage articles, interdisciplinary in nature. The realm of International Journal of Engineering (IJE) extends, but not limited, to the following:

To build its International reputation, we are disseminating the publication information through Google Books, Google Scholar, Directory of Open Access Journals (DOAJ), Open J Gate, ScientificCommons, Docstoc and many more. Our International Editors are working on establishing ISI listing and a good impact factor for IJE.

The initial efforts helped to shape the editorial policy and to sharpen the focus of the journal. Started with Volume 13, 2021, IJE will appear with more focused issues. Besides normal publications, IJE intend to organized special issues on more focused topics. Each special issue will have a designated editor (editors) – either member of the editorial board or another recognized specialist in the respective field.

We are open to contributions, proposals for any topic as well as for editors and reviewers. We understand that it is through the effort of volunteers that CSC Journals continues to grow and flourish.

IJE LIST OF TOPICS

The realm of International Journal of Engineering (IJE) extends, but not limited, to the following:

- Aerospace Engineering
- Biomedical Engineering
- Civil & Structural Engineering
- Control Systems Engineering
- Electrical Engineering
- Engineering Mathematics
- Environmental Engineering
- Geotechnical Engineering
- Manufacturing Engineering
- Mechanical Engineering
- Nuclear Engineering
- Petroleum Engineering
- Telecommunications Engineering
- Agricultural Engineering
- Chemical Engineering
- Computer Engineering
- Education Engineering
- Electronic Engineering
- Engineering Science
- Fluid Engineering
- Industrial Engineering
- Materials & Technology Engineering
- Mineral & Mining Engineering
- Optical Engineering
- Robotics & Automation Engineering

CALL FOR PAPERS

Volume: 13 - Issue: 2

i. Paper Submission: April 30, 2021

ii. Author Notification: May 31, 2021

iii. Issue Publication: June 2021

CONTACT INFORMATION

Computer Science Journals Sdn Bhd

B-5-8 Plaza Mont Kiara, Mont Kiara

50480, Kuala Lumpur, MALAYSIA

Phone: 006 03 6204 5627

Fax: 006 03 6204 5628

Email: cscpress@cscjournals.org

CSC PUBLISHERS © 2021
COMPUTER SCIENCE JOURNALS SDN BHD
B-5-8 PLAZA MONT KIARA, MONT KIARA
50480, KUALA LUMPUR
MALAYSIA

PHONE: 006 03 6204 5627
FAX: 006 03 6204 5628
EMAIL: cscpress@cscjournals.org