

Analysis of WiMAX Physical Layer Using Spatial Multiplexing Under Different Fading Channels

Pavani Sanghoi

Department of Electronics and Communication Engineering
Lovely Professional University
Punjab, INDIA

pavani.sanghoi@gmail.com

Lavish Kansal

Department of Electronics and Communication Engineering
Lovely Professional University
Punjab, INDIA

lavish.s690@gmail.com

Abstract

WiMAX is defined as Worldwide Interoperability for Microwave Access by the WiMAX Forum and its industry. WiMAX is basically a wireless digital communication system which is also known as IEEE 802.16 standard intended for wireless "metropolitan area networks". WiMAX is based upon OFDM multiplexing technique. It was developed in order to provide high speed data rates to the users located in those areas also where broadband wireless coverage is not available. MIMO systems also play an important role in the field of wireless communication by allowing data to be transmitted and received over different antennas. WiMAX-MIMO systems are developed to improve the performance of WiMAX system. This paper analyzes WiMAX-MIMO system for different modulation schemes with different CC code rates under different fading channels (Rician and Nakagami channel). Spatial Multiplexing technique of MIMO system is used for the simulation purpose. Analysis has been done in the form of Signal-to Noise Ratio (SNR) vs Bit Error Rate (BER) plots.

Keywords: BWA, WiMAX, MIMO, SNR, BER, FEC, CC, PHY

1. INTRODUCTION

WiMAX is a wireless technology which is capable of delivering very high data rates over very long distances [1]. The working of WiMAX standard is based upon OFDM technique hence improving the robustness of the whole system. This seems to be an ideal technology to apply to the problem space of the residential wireless local loop, where low-rate wired infrastructure limits the types of capabilities that can be enjoyed by residential consumer. Communications done with direct visibility in the frequency band from 10 to 66 GHz, were dealt by IEEE 802.16 standard that specifies working in a lower frequency band 2- 11 GHz [2], [3]. This standard is known as IEEE 802.16a. IEEE 802.16d standard which is a variation of IEEE 802.16a standard was basically about optimizing the power consumption of mobile device. IEEE 802.16e standard is an amendment to IEEE 802.16-2004 and adds portability to the mobile device and is oriented to both stationary and mobile deployments. WiMAX standards based projects works equally well with both the above IEEE standards [4], [5].

WiMAX standard is able to provide broadband wireless access (BWA) [6] up to 30 miles (50 km) for fixed stations, and 3 - 10 miles (5 - 15 km) for mobile stations. The prime advantages of the WiMAX standard are enabling the adoption of advanced radio features in a uniform fashion and reducing the costs for all the radios made by companies. The first version of the WiMAX standard operates in the 10–66GHz frequency band that requires line-of-sight (LOS) towers [7]. Due to this limitation, the IEEE opted for single-carrier modulation. This Fixed WiMAX standard was developed in 2001 and the air interface specifications were given in 2004. Later the standard extended its operation through different PHY specification 2-11 GHz frequency band enabling non line of sight (NLOS) connections, which require techniques that efficiently mitigate the impairment of fading and multipath [8]. This standard is known as Mobile WiMAX and was developed in 2005 and its air interface specifications were given in 2009.

MIMO systems enable the use of multiple antennas at the transmitter and the receiver side in order to improve the spectral efficiency, throughput and link transmit power that attracted most of the attention in the field of wireless communication. Various techniques are included in the MIMO systems that provide diversity as well as multiplexing gain hence improving the BER and SNR of the system. Diversity technique when used is able to provide diversity gain by placing spatially separated antennas in dense multipath scattering environment whereas when spatial multiplexing technique is used, it provides multiplexing gain hence improving the capacity of the system.

The paper is organized as follows: WiMAX Physical layer specifications are explained in section II. WiMAX model for Physical layer is described in detail in section III. An overview of the MIMO system is presented in Section IV. Different techniques of MIMO system are provided in section IV. A detailed explanation of the proposed WiMAX-MIMO system can be studied in section V. Results and simulations are analyzed in section VI. At the end final conclusion drawn on the basis of the results is given in section VII.

2. WIMAX PHYSICAL LAYER SPECIFICATIONS

The IEEE 802.16 PHY for the WiMAX standard mainly involves three specifications that are suited for different operational environments. The standard recommends the Wireless MAN-SC PHY for frequencies from 10 to 66 GHz, where SC means single-carrier modulation. The channel bandwidth for this standard is 25 MHz or 28 MHz, and the data rates can exceed 120 Mb/s.

Two alternatives have been specified for the frequency band below 11 GHz: Wireless MAN-OFDM and Wireless MAN- OFDMA. In this low frequency range, the wavelength is relatively long; hence it utilizes a Non-LOS (NLOS) communication that leads to more of fading and multipath propagation in both these specifications.

2.1 Wireless MAN-SC PHY

This specification supports both TDD as well as FDD to allow flexible spectrum usage and operates in the 10-66 GHz frequency range. Each frame of the TDD consists of uplink and downlink subframes. The uplink channel is divided into various time slots controlled by the MAC layer present in the base station whereas the downlink channel uses TDM multiplexing technique in which information from multiple mobile stations (MS) are multiplexed into one independent stream. The system structures for the uplink and downlink transmitters are similar for both TDD and FDD.

2.2 Wireless MAN-OFDM

This specification uses OFDM multiplexing technique. OFDM is a multicarrier modulation in which the subcarriers are selected in such a way that they all are orthogonal to each other over the entire symbol duration; thereby eliminating inter-carrier interference in between the symbols. The OFDM PHY is based upon OFDM modulation and is designed for NLOS environment [9]. If we consider the frequency domain, an OFDM symbol consists of total of 256 subcarriers. This air interface specification provides multiple access to different stations through time-division multiple access (TDMA).

2.3 Wireless MAN-OFDMA

The Wireless MAN-OFDMA PHY is also designed for NLOS operation in the frequency band of 2-11 GHz for licensed bands. The size of fast Fourier transform (FFT) of OFDMA PHY can be 128, 512, 1024, or 2048. The OFDMA PHY supports QPSK, 16-QAM, and 64-QAM modulation schemes. This air interface provides multiple access to the users by assigning a subset of the carriers to an individual receiver unlike to that of OFDM.

An OFDMA symbol is constructed from various carriers:

- Data carriers – used mainly for data transmission.
- Pilot carriers – these carriers signifies that the magnitude and phase of these carriers are known to the receiver. They are used for channel estimation purposes.

- Null carriers – these carriers prevent the leakage of energy into the adjacent channels.

3. WIMAX MODEL FOR PHYSICAL LAYER

WiMAX Physical layer has number of adaptive features that provides robustness and capacity improvement in the high speed data transmission. The role of the WiMAX PHY layer is to encode the input data of binary digits that represent MAC frames into signals and to transmit and receive these signals so that they are suitable for the wireless channel. This task is done with the help of various processes. The block diagram of WiMAX Physical layer is shown in figure 4 [10]. Now function of each of the block is explained one by one in detail.

3.1 Randomization

This is the first step in the WiMAX Physical layer that involves scrambling or reordering of the input data to generate a random sequence such that coding efficiency and integrity can be improved. Randomization is performed on each burst of the input data in order to avoid long sequences of ones and zeros that continuously appears in the input data. It mainly operates on bit to bit basis. Randomization involves changing the position and state of the bits. It is implemented with the help of a Pseudo Random Binary Sequence (PBRS) generator with a generator polynomial of $1 + x^{14} + x^{15}$ with XOR gates in feedback configuration.

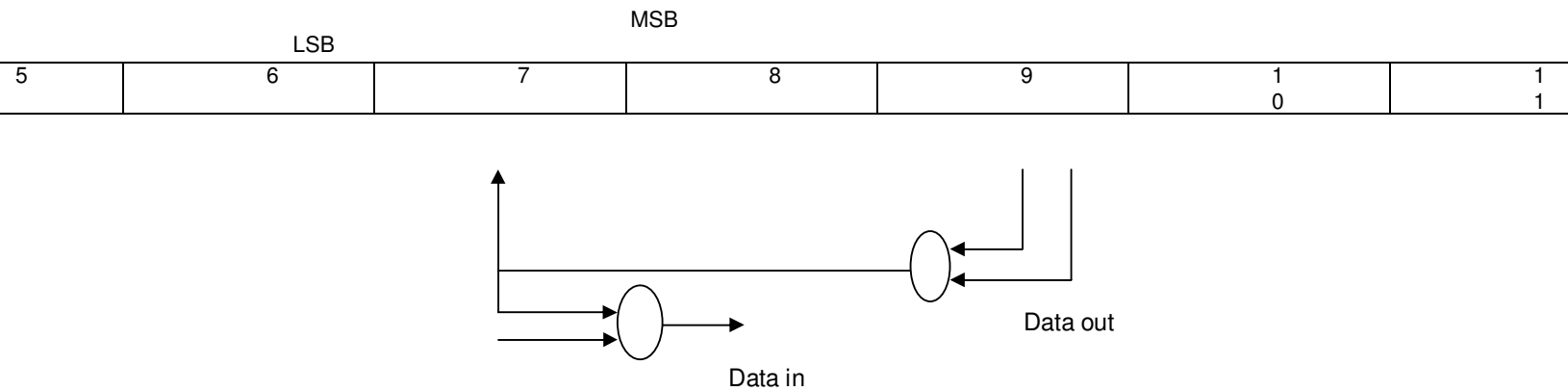

FIGURE 1: PBRS generator for Randomization

3.2 Forward Error Correction (FEC)

The incoming data in the bit format from the randomizer are applied to the FEC encoder in order to generate the codewords. FEC encoding is done on both sides, the uplink and downlink bursts of data and consists of an outer RS code and an inner convolutional code. This encoding is used for error detection and error correction and is included in the channel coding process.

3.2.1 RS codes

RS error correction is basically a coding scheme that works by first constructing a polynomial from the data symbols that are to be transmitted and then sending an oversampled version of polynomial. These codes are used for variable block size of data and error correcting capabilities. RS codes basically correct block errors. The encoding process for a RS encoder is based upon Galois field computation in order to add the redundant bits to the original bit stream. WiMAX is based on GF (2^8) which is specified as RS (N = 255, K = 239, T = 8)

Where:

N = Number of Bytes after encoding

K = Data Bytes before encoding

T = Number of bytes that can be corrected

3.2.2 Convolution Codes (CC)

These convolutional (CC) codes are used to correct the random errors instead of block errors [7] and are easier to implement compared to RS codes. These codes also introduce redundant bits into the data stream but by using linear shift memory register (k). These codes are specified by CC (m, n, k) in which each m-bit information symbol which is to be encoded is transformed into an n-bit information symbol. Code rate of a CC encoder can be specified as m/n. Puncturing is a process of deleting additional bits from the output stream of a low-rate encoder so as to reduce the amount of data to be transmitted hence forming higher order code rates like 1/2, 2/3, 3/4 and 5/6. This process is mainly used to create variable code rates to ensure error correction capability.

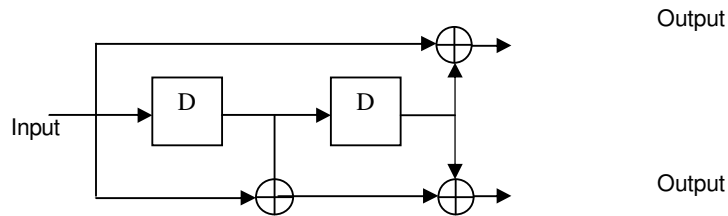

FIGURE 2: Convolutional Encoder

Viterbi algorithm is used at the receiver side for decoding the encoded sequence. Channel coded symbols are decoded at the receiver side of WiMAX Physical layer with the help of Viterbi algorithm. This algorithm performs maximum likelihood (ML) decoding of the received symbols by retracing all the state transitions of the CC encoder in the trellis diagram but the complexity of the decoder increases with the constraint length.

3.3 Interleaving

Interleaving is mainly done to reduce the probability of burst errors. The main purpose is to map the bits on the non-adjacent subcarriers hence removing burst errors. It differs from the randomization process in a way that it changes only the position of the bits rather than state of the bits. Main cause of burst errors is multipath distortion that leads to distortions in the original signal. There are basically two types of interleaving:

3.3.1 Block Interleaving

The encoded data is interleaved by a block interleaver. The block size depends upon the number of encoded bits per sub channel in one OFDM symbol. A block interleaver can be described by a matrix into which the data is written in column format and read in row wise format, or vice versa. It is defined by two permutations. The first one ensures that the adjacent coded bits are mapped onto non-adjacent subcarriers whereas second one signifies that adjacent coded bits are mapped onto less or more significant bits of the constellation hence avoiding long sequence of bits. Same type of permutation is done at the receiver side to rearrange the data bits into the correct sequence again. Index of coded bits after second permutation is used during the modulation process which is the next step in the physical layer.

3.3.2 Convolutional Interleaving

This type of interleaving operates on continuous stream of bits. The convolutional interleaver operates by writing the received bits into the commutator on the left, and reading the bits out from the commutator on the right side. The delay elements D are added after each clock cycle of the commutators is completed. The main benefit of using a convolutional interleaver is that it requires half of the memory required in comparison to a block interleaver in order to achieve the same interleaving depth. This can be significant for long interleaver depths.

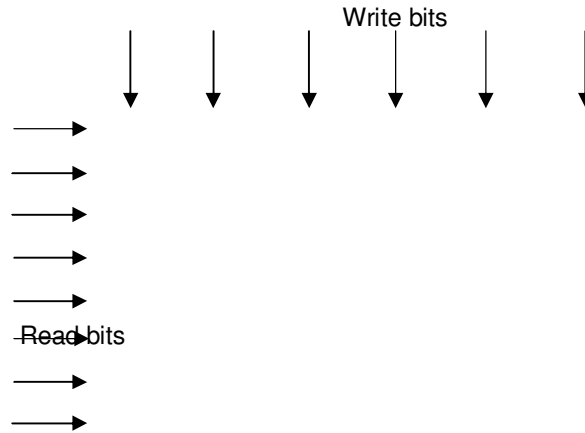

FIGURE 3: Bit write and read operation of Block Interleaver

3.4 Modulation

In this block, the random values are passed through the adaptive modulation schemes according to the constellation mapped. The data to be modulated depends upon their size and on the basis of different modulation schemes to be used like BPSK, QPSK, 16QAM and 64QAM. Digital modulation schemes are being used in which the amplitude and phase of the signal changes in accordance with the carrier signal. It basically involves mapping of digital

<i>B0</i>	<i>B8</i>	<i>B16</i>	<i>B24</i>	<i>B32</i>	<i>B40</i>
<i>B1</i>	<i>B9</i>	<i>B17</i>	<i>B25</i>	<i>B33</i>	<i>B41</i>
<i>B2</i>	<i>B10</i>	<i>B18</i>	<i>B26</i>	<i>B34</i>	<i>B42</i>
<i>B3</i>	<i>B11</i>	<i>B19</i>	<i>B27</i>	<i>B35</i>	<i>B43</i>
<i>B4</i>	<i>B12</i>	<i>B20</i>	<i>B28</i>	<i>B36</i>	<i>B44</i>
<i>B5</i>	<i>B13</i>	<i>B21</i>	<i>B29</i>	<i>B37</i>	<i>B45</i>
<i>B6</i>	<i>B14</i>	<i>B22</i>	<i>B30</i>	<i>B38</i>	<i>B46</i>
<i>B7</i>	<i>B15</i>	<i>B23</i>	<i>B31</i>	<i>B39</i>	<i>B47</i>

data onto analog form such that the signal can be transmitted over the channel. In this paper we are concerned with the digital modulation techniques. Various digital modulation techniques can be used for data transmission, such as M-PSK and M-QAM, where M is the number of constellation points in the constellation diagram [11]. Inverse process of modulation called demodulation is done at the receiver side to recover the original transmitted digital information.

3.4.1 M-PSK Modulation

In M-ary PSK modulation, the amplitude of the transmitted signals was constrained to remain constant, thereby yielding a circular constellation [12]. The signal set for this modulation is:

$$X_i(t) = \sqrt{2E_s/T_s} \cos(2\pi * f_c t + 2(i-1)/M) \quad i=1,2,\dots,M \text{ \& } 0 < t < T_s$$

Where E_s the signal energy per symbol T_s is the symbol duration, and f_c is the carrier frequency. This phase of the carrier takes on one of the M possible values, namely

$$\theta_i = 2(i-1)\pi/M \quad \text{where } i=1,2,\dots,M$$

3.4.2 M-QAM Modulation

A new modulation scheme called quadrature amplitude modulation (QAM) is obtained by allowing the amplitude to vary with the phase. This is the most popular modulation technique used in various wireless standards. It combined with ASK and PSK which has two different signals sent concurrently on the same carrier frequency but one should be shifted by 90° with respect to the other signal. At the receiver end, the signals are demodulated and the results are combined to get the transmitted binary input. The transmitted M-ary QAM symbol l :

$$X_i(t) = \sqrt{2/T_s} a_n \cos(2\pi f_{ct}) - \sqrt{2/T_s} b_n \sin(2\pi f_{ct}) \quad i=1,2,\dots,M \text{ \& } 0 < t < T_s$$

where a_n and b_n are amplitudes taking on the values and

$$a_n, b_n = \pm a, \pm 3a, \dots, \pm(\log_2 M - 1)a$$

where M is assumed to be a power of 4.

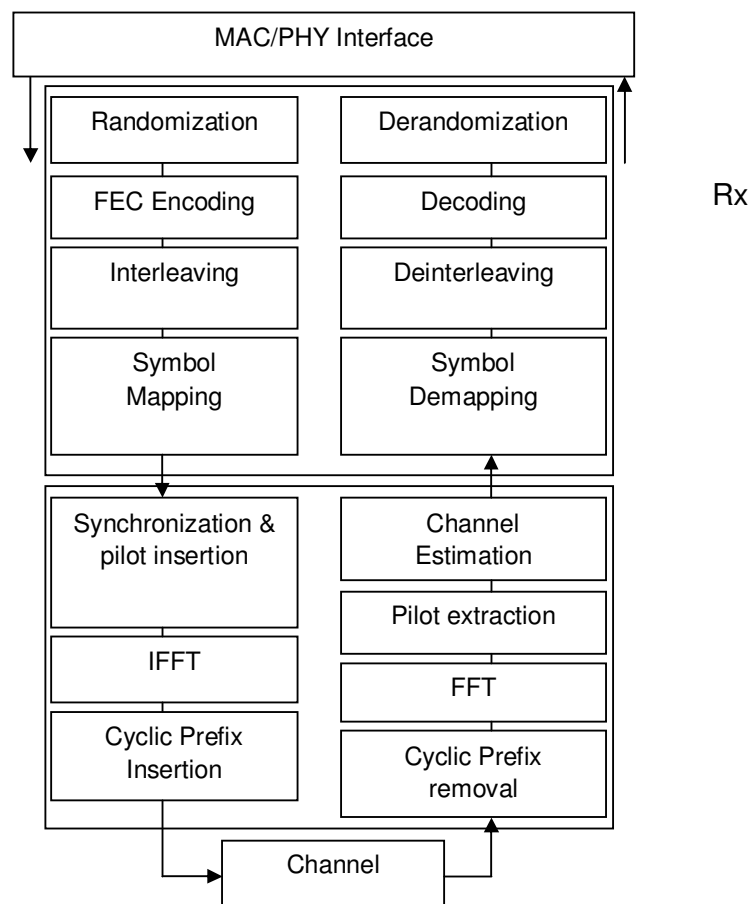

FIGURE 4: WiMAX Model for Physical Layer

3.5 Pilot Insertion

Pilot carriers are inserted in the modulated symbols for carrying out the channel estimation as well as the synchronization process at the receiver side of the WiMAX Physical layer. Those

pilot carriers are inserted whose magnitude and phase are known to the receiver for recognizing the channel matrix. These are used to track the residual phase error in the transmitted symbols after frequency correction. If this correction is not done, then the symbols start rotating with some angle that can be positive or negative.

3.6 Inverse Fast Fourier Transform (IFFT)

The main purpose of IFFT is to convert frequency domain to time domain in order to maintain the orthogonality condition between the transmitted symbols. IFFT generates samples of waveform having frequency components that provides the orthogonality with minimum frequency separation between the transmitted symbols. Output of IFFT is the total N sinusoidal signals that make a single OFDM symbol.

FFT works almost opposite to IFFT in a way that it converts time domain to frequency domain. Fast Fourier Transform (FFT) reduces the number of computations to the order of $N \log N$ compared to N^2 in DFT. The FFT algorithm is most efficient when N is a power of two. The result of the FFT contains the frequency domain data and the complex transformed result.

3.7 Cyclic Prefix

Cyclic prefix is added to the signals in order to reduce the delay caused due to the multipath propagation phenomenon. It is added at the beginning of the signal before transmitting the signal. It makes the symbols periodic in nature thereby converting linear convolution to circular convolution in a way that the symbol is preceded by the periodic extension of the symbol itself. The ISI is eliminated with the help of CP addition by adding guard bands thus avoiding interference in between the symbols when the CP length L is greater than multipath delay. The ratio of CP time to OFDM symbol time, G can be equal to 1/32, 1/6, 1/8 and 1/4.

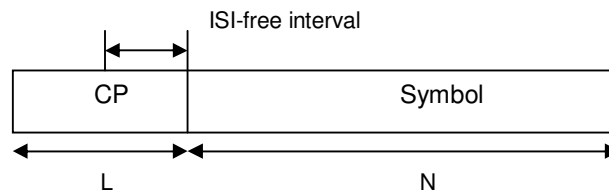

FIGURE 5: Cyclic Prefix Addition

3.8 Communication Channels

Channel is a transmission medium between the transmitter and receiver side of WiMAX. Channel can be air or space but it induces fading as well as distortions in the transmitted signal in such a way that the received signal is not same as that of transmitted signal but is a combination of reflected, diffracted and scattered copies of the transmitted signal. These copies are called multipath signal components. Rician and Nakagami fading channels have been taken into consideration for the analysis purpose.

3.8.1 Rician Channel

The direct path is the strongest component that goes into deep fades compared to multipath components when there is line of sight. Such signal is approximated with the help of Rician distribution. This distribution changes into Rayleigh distribution when there is no line of sight.

The Rician distribution is given by:

$$P(r) = \left(\frac{r}{\sigma^2}\right) \exp\left(-\frac{r^2 + A^2}{2\sigma^2}\right) I_0\left(\frac{Ar}{\sigma^2}\right) \quad , \quad \text{for } (A \geq 0, r \geq 0)$$

where A denotes the peak amplitude of the dominant signal and $I_0[.]$ is the modified Bessel function of the first kind and zero-order.

3.8.2 Nakagami Channel

Rayleigh fading falls short in describing the long-distance fading effects which was corrected by Nakagami by formulating a parametric gamma distribution-based density function thereby reducing the effects of multipath propagation. It provides a better explanation to more severe conditions than the Rayleigh and Rician fading model and thus fits better in the mobile communication channel data. This fading was developed to characterize the amplitude of fading channels. Nakagami fading can be described by the PDF which is given as:

$$f_r(r) = \left(\frac{2}{\Gamma(m)}\right) \left(\frac{m}{\Omega}\right)^m r^{2m-1} e^{-\frac{mr^2}{\Omega}} u(r) \quad , \quad \text{for}$$

$$m < 0.5 \Omega^2 / E[(R^2 - \Omega^2)^2]$$

Where the parameter Ω and the fading figure m are defined via:

$$\Omega = E\{R^2\} \quad , \quad m = \frac{\Omega^2}{E[(R^2 - \Omega^2)^2]}$$

And $\Gamma[n]$ is the standard Gamma function defined via:

$$\Gamma[n] = \int_0^{\infty} e^{-x} x^{n-1} dx$$

3.9 Receiver Side

At the receiver side of the Physical layer, a reverse process (including deinterleaving and decoding) is performed on the received signal to obtain the original data bits that were transmitted.

4. MULTI INPUT MULTI OUTPUT (MIMO) SYSTEMS

Multiple Input Multiple Output (MIMO) system has been the most promising wireless technology to improve the performance of a wireless radio link. MIMO transmission system is the most recent approach which is currently in use in order to deliver high-rate wireless communication. This technology was firstly introduced at Stanford University (1994) and Lucent (1996). MIMO technology takes advantage of a radio-wave phenomenon called multipath where transmitted information bounces off walls, ceilings, and other objects, reaching the receiving antenna multiple times via different angles and at slightly different times. MIMO improves the capacity and combats the fading effects by using different diversity techniques [13]. MIMO systems significantly improve the spectral efficiency of a system with the help of an additional spatial dimension. It is a wireless technology that uses multiple transmitters and receivers to transfer more data at the same time.

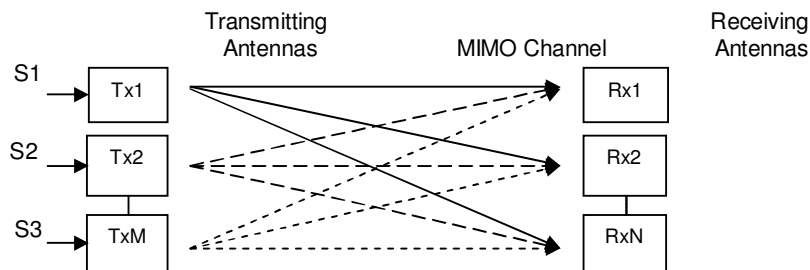

FIGURE 6: Block Diagram of MIMO system with M Transmitters and N Receivers

5. MIMO TECHNIQUES

MIMO includes different techniques that can improve the performance of the MIMO system. MIMO systems can be implemented in a number of different ways so as to attain a diversity gain to combat signal fading or a capacity gain to improve the SNR of the system.

5.1 Spatial Diversity

Diversity is a technique of transmitting multiple copies of the same transmitted signal through different antennas [14]. This technique requires different number of signal transmission paths which are known as diversity branches and each diversity branch carries the same type of information with dissimilar multipath fading characteristics. Diversity requires a combining circuitry so as to combine the signals from each of the diversity branch by selecting only the best signal out of all the different received signals. The signal is coded using a technique called as space-time coding which is specified by a matrix in which rows represents the number of time slots whereas columns represents the transmission period [15]. Diversity techniques are mainly used to reduce the multipath fading phenomenon effects and improve the reliability of transmission process without sacrificing the total bandwidth of the spectrum and without increasing the transmitted power of the transmitted signal.

The main idea behind this technique is that, when two or more independent signals are taken, these signals fades in such a manner such that some signals are less attenuated while the remaining others are severely attenuated due to multipath propagation that occurs in the transmission medium. This diversity technique receives multiple replicas of the transmitted signal at the receiver as same information is transmitted through different antennas such that the received signal is the coherent combination of the transmitted signals but with small correlation in fading statistics. Diversity techniques [16] improve the robustness of the wireless communication link in terms of BER by exploiting the multiple paths between transmitting and receiving antennas.

5.2 Spatial Multiplexing

The concept of spatial multiplexing technique of MIMO systems is to divide and transmit a data stream into several branches and transmit them via several independent channels in space dimension and different bits are transmitted via different transmitting antennas. One of the main advantage of MIMO spatial multiplexing technique is the fact that it is able to provide additional data capacity thus providing capacity gain compared to diversity gain in spatial diversity technique. MIMO spatial multiplexing achieves multiplexing gain by utilizing the multiple paths and using them as "channels" to carry the data such that receiver receives multiple data at the same time thus improving the system capacity. The spatial multiplexing involves transmitting different symbols from each of the transmitting antenna and the receiver discriminates these symbols with the help of spatial selectivity, that each transmitting antenna has a different spatial signature at the receiver side. This allows increase in the number of information symbols per MIMO symbol at the receiver side; depending upon the transmission technique which is used. In MIMO spatial multiplexing, the number of receiving antennas must be equal to or greater than the number of transmit antennas such that data can be transmitted over different antennas. This spatial multiplexing technique includes layered architectures that improve the capacity of the MIMO system. One such technique is known as V-BLAST [17] which was developed by Bell Laboratories. In this paper spatial multiplexing technique is taken into consideration for analyzing the system under different fading channels.

5.3 Beamforming

Beamforming is the third technique of MIMO systems that exploits the knowledge of the channel at the transmitter end. It mainly decomposes the channel coefficient matrix using SVD technique and then uses these decomposed unitary matrices as pre as well as post filters at the transmitter and the receiver in order to achieve near capacity. Beamforming technique involves directing the signal beam in the desired direction in a way that the signal

going in the desired direction increases and signal going in the other undesired directions reduces. Beamforming provides gain which is in between diversity and multiplexing gain. In single-layer beamforming, same signal is being emitted from the transmitting antennas with appropriate phase angle and gain weightings such that the transmitted signal power is maximized at the receiver side. The main benefits of beamforming technique are increasing the received signal gain, by making signals add up constructively that are emitted from different antennas, and reducing the multipath fading effect which is caused when the transmitted signal passes through the channel [18].

6. WiMAX-MIMO SYSTEMS

WiMAX-MIMO systems are developed in order to attain the benefits of both the WiMAX protocol as well as the MIMO systems in such a way that high speed broadband internet access can be provided to the users [19]. This paper is based upon combining WiMAX protocol with the spatial multiplexing technique of MIMO systems such that multiplexing gain can be obtained hence improving the SNR of the WiMAX-MIMO system.

Spatial multiplexing involves transmitting different information over different transmitting antennas such that the received signal combines all the transmitted signals hence improving the SNR of the system [20]. The WiMAX-MIMO system block diagram is given in figure 7. Combining both WiMAX and MIMO technology provides high data rates for transmission thus improving the performance of WiMAX-MIMO system when compared with simple WiMAX system. This proposed WiMAX-MIMO system provides better BER and SNR performance in comparison to WiMAX without employing MIMO systems. Spatial multiplexing technique has been used to attain capacity gain to combat signal fading. WiMAX is combined with the MIMO system by employing STBC Encoder and Decoder at the transmitter and receiver side of the WiMAX PHY layer before and after the channel respectively.

This paper analyzes the spatial multiplexing technique of MIMO systems with the WiMAX protocol in order to achieve higher data rate transmission by lowering down the Signal to Noise Ratio of the system to achieve better performance and results. Results are obtained for the Rician and Nakagami fading channels.

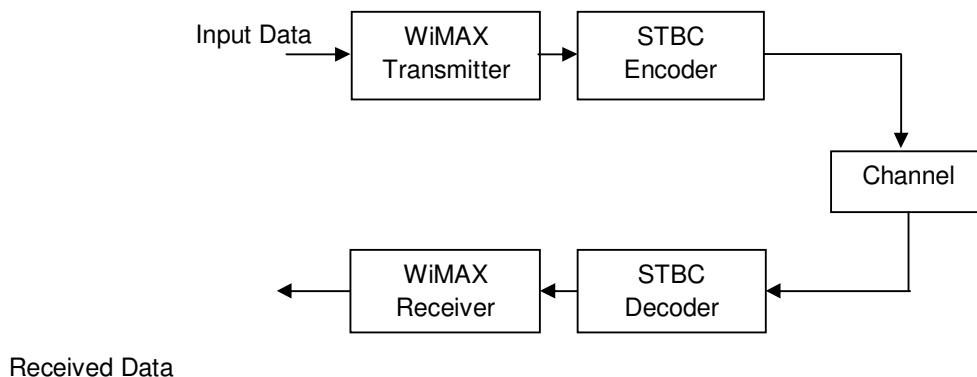

FIGURE 7: WiMAX-MIMO System

7. RESULTS AND SIMULATIONS

This paper analyzes the behavior of WiMAX-MIMO systems under different modulation schemes with different CC code rates for different fading channels i.e. Rician and Nakagami channels. Results are shown in the form of SNR vs BER plots. The simulations are done for Spatial Multiplexing technique is used so as to improve the performance of the WiMAX-MIMO

systems in comparison to simple WiMAX standard. Firstly WiMAX physical layer has been simulated and then it is combined with the spatial multiplexing technique of MIMO systems.

7.1 BER Analysis for Rician Channel

In this section BER analysis of WiMAX-MIMO with Spatial Multiplexing is done for different Modulations over Rician fading channel.

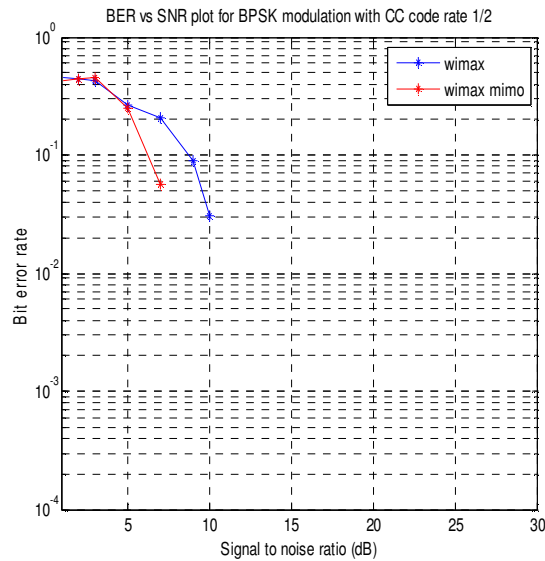

(a) BPSK with CC code rate 1/2

In this graph we are able to achieve 3dB improvement in SNR is shown when we employ Spatial Multiplexing technique of MIMO in WiMAX in the presence of Rician channel.

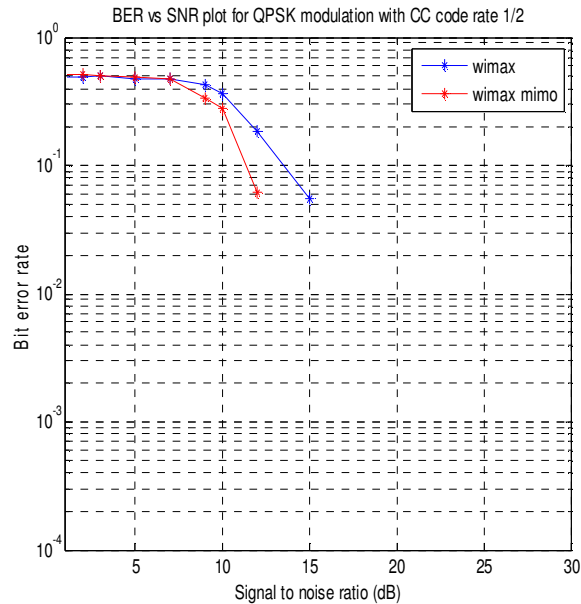

(b) QPSK with CC code rate 1/2

QPSK modulation with CC code rate 1/2 provides 3dB improvement in SNR when combining WiMAX with MIMO Spatial Multiplexing technique. Rician channel is used for the analysis purpose.

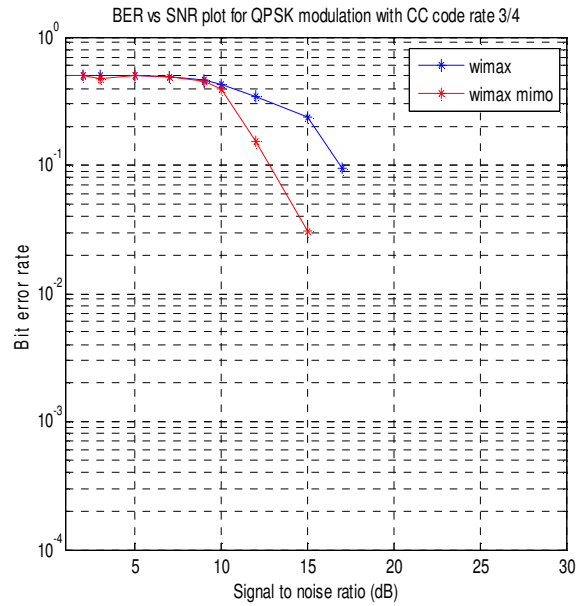

(c) QPSK with CC code rate 3/4

Using QPSK modulation with CC code rate of 3/4, SNR improvement of 2dB can be seen in WiMAX-MIMO system compared to simple WiMAX standard.

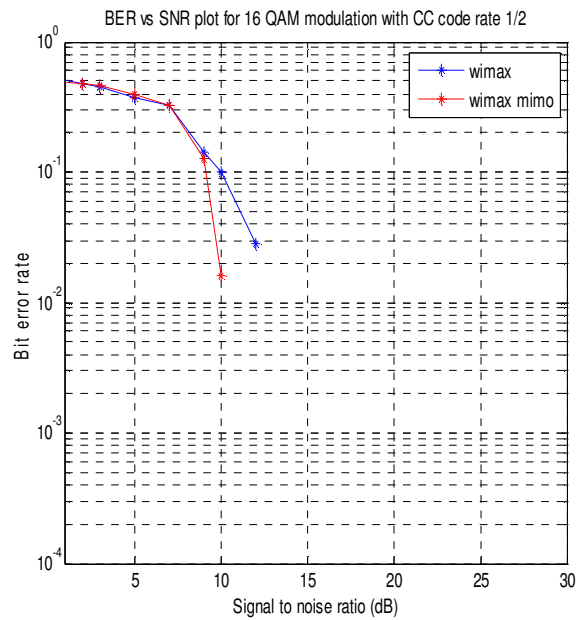

(d) 16QAM with CC code rate 1/2

As we can see from the graph, SNR improvement of 2dB is there using WiMAX protocol with Spatial Multiplexing technique of MIMO technology in the presence of Rician channel. Performance of simple WiMAX is improved using MIMO.

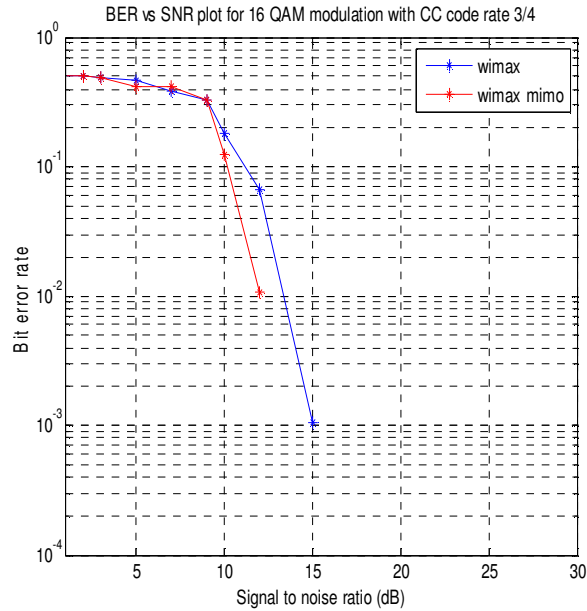

(e) 16 QAM with CC code rate 3/4

Again as we can see there is an improvement of 3dB in the SNR value using Rician channel with the combination of WiMAX standard with the MIMO technology.

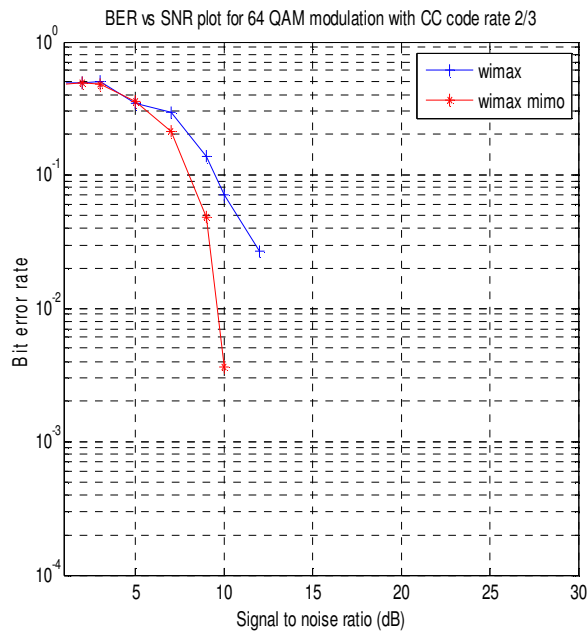

(f) 64 QAM with CC code rate 2/3

SNR improvement of 2dB incase of 64QAM modulation with CC code rate 2/3 can be seen when we use WiMAX protocol with the Spatial Multiplexing technique of MIMO in the presence of Rician channel.

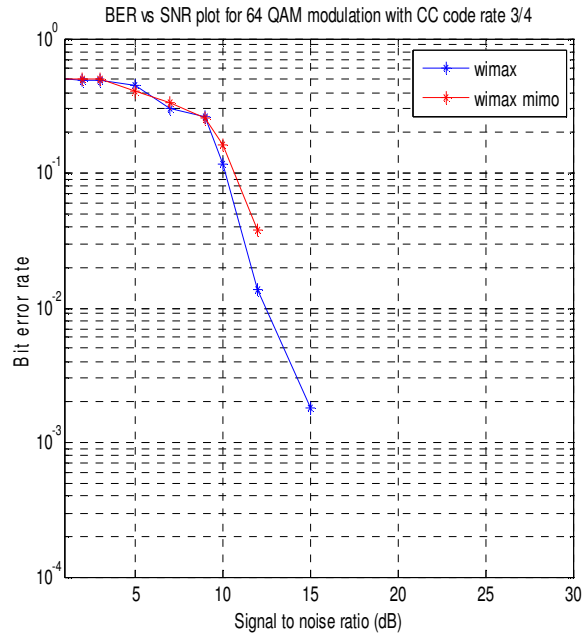

(g) 64 QAM with CC code rate 3/4

This graph shows an SNR improvement of 3dB using WiMAX-MIMO system in the presence of Rician channel for 64QAM modulation with code rate of 3/4.

FIGURE 8: BER vs SNR plots for Rician channel

- a) BPSK code rate 1/2 b) QPSK code rate 1/2 c) QPSK code rate 3/4 d) 16 QAM code rate 1/2
- e) 16 QAM code rate 3/4 (f) 64 QAM code rate 2/3 (g) 64 QAM code rate 3/4

The performance of WiMAX-MIMO system with different modulations and different CC code rates have been presented in the form of BER vs SNR plots over Rician channel in Figure 8 (a)–(g). Each graph shows an improvement in the SNR value using spatial multiplexing technique of MIMO system.

TABLE 1: SNR improvement in Rician channel by using Spatial Multiplexing in WiMAX

MODULATION	SNR Improvement using Rician channel (dB)
BPSK code rate 1/2	3dB
QPSK code rate 1/2	3dB
QPSK code rate 3/4	2dB
16 QAM code rate 1/2	2dB
16 QAM code rate 3/4	3dB
64QAM code rate 2/3	2dB
64QAM code rate 3/4	3dB

7.2 BER Analysis for Nakagami Channel

In this section BER analysis of WiMAX-MIMO system with Spatial Multiplexing is done for different Modulations over Nakagami fading channel. Analysis has been done in the form of BER vs SNR plots thus showing an improvement in the SNR value.

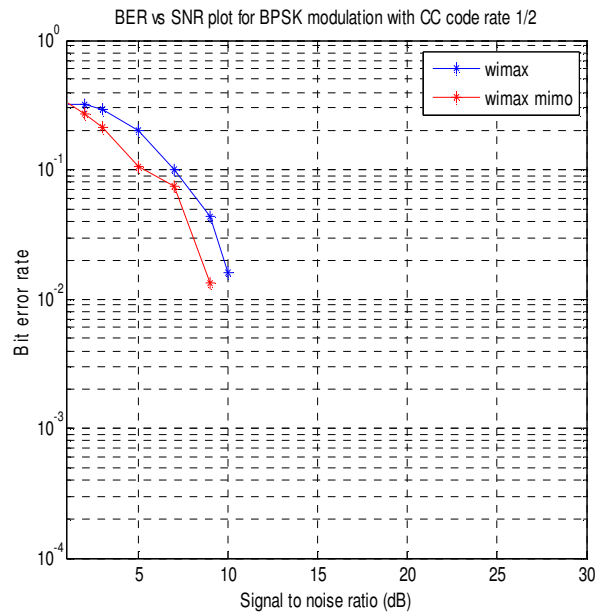

(a) BPSK with CC code rate 1/2

We are able to achieve 1dB improvement in SNR when we employ Spatial Multiplexing technique of MIMO system in WiMAX in the presence of Nakagami channel.

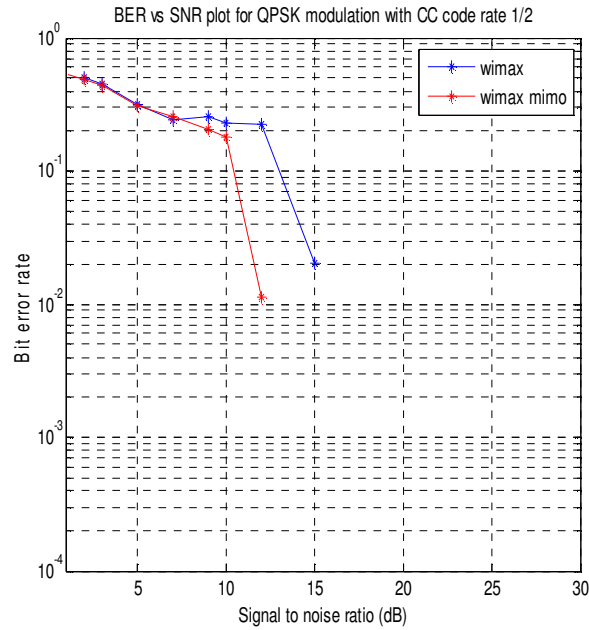

(b) QPSK with CC code rate 1/2

QPSK modulation with CC code rate of 1/2 provides 3dB improvement in SNR when combining WiMAX with MIMO Spatial Multiplexing technique. For the analysis purpose, Nakagami fading channel is used.

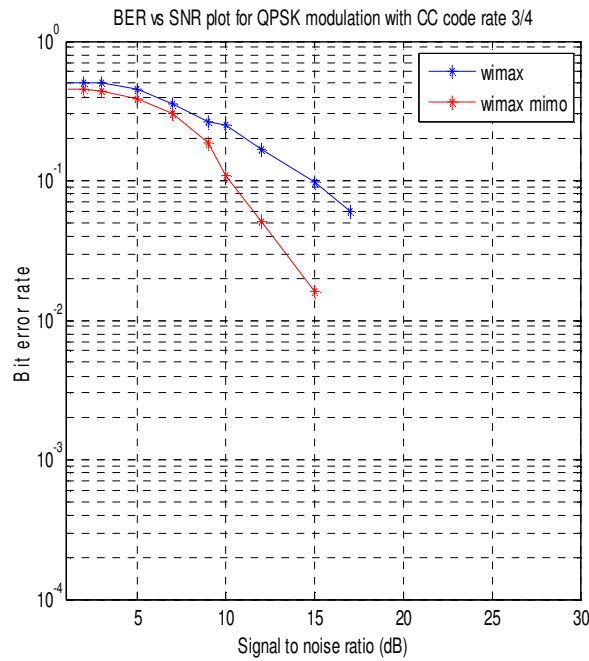

(c) QPSK with CC code rate 3/4

Using QPSK modulation with CC code rate of 3/4, SNR improvement of 2dB can be seen in WiMAX-MIMO system when it is compared to simple WiMAX standard.

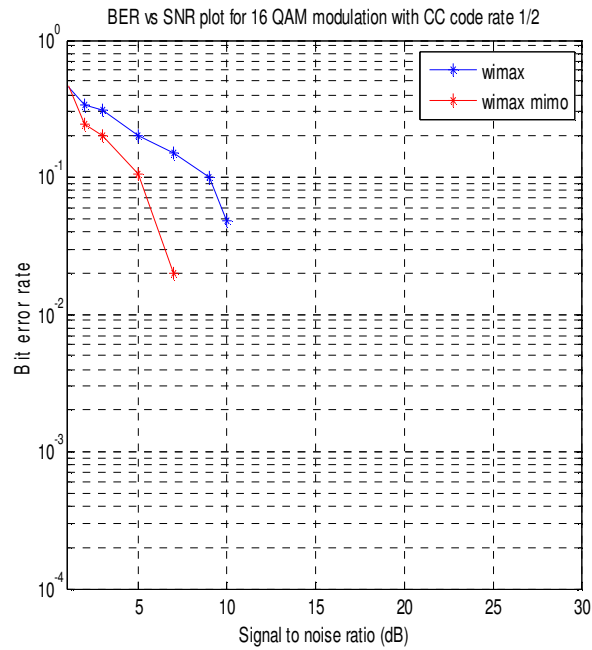

(d) 16QAM with CC code rate 1/2

SNR improvement of 3dB can be seen using WiMAX protocol with Spatial Multiplexing technique of MIMO technology in the presence of Nakagami fading channel.

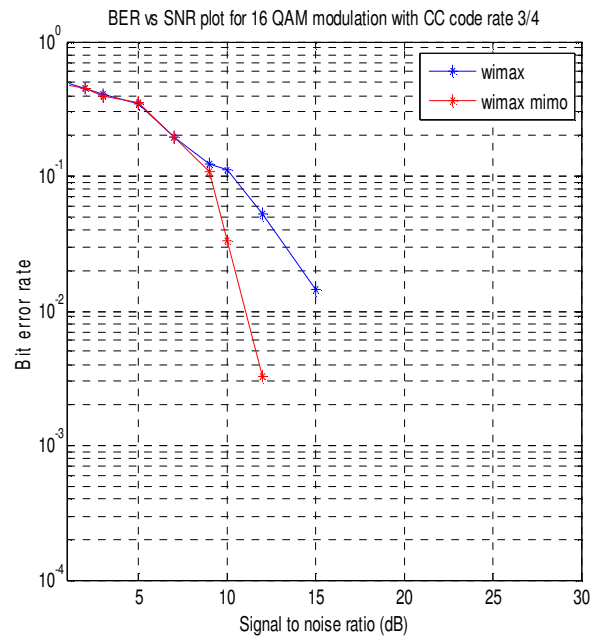

(e) 16 QAM with CC code rate 3/4

Again as we can see that there is an improvement of 3dB in the SNR value using Nakagami channel with the combination of WiMAX standard with the MIMO technology using 16 QAM modulation with CC code rate 3/4.

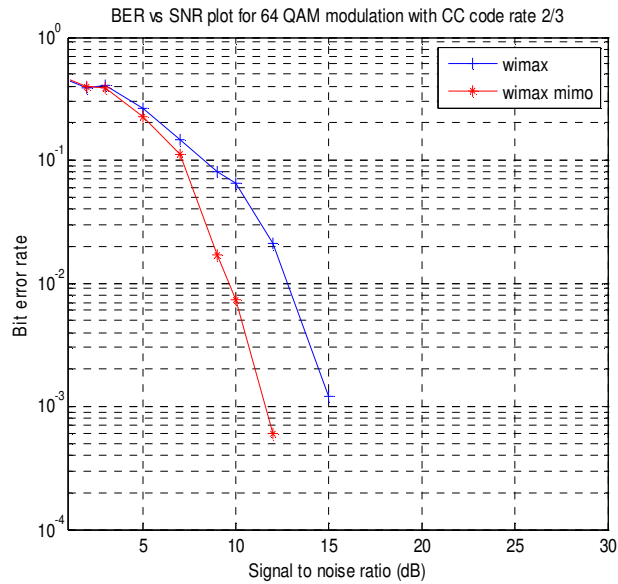

(f) 64 QAM with CC code rate 2/3

SNR improvement of 3dB is observed incase of 64QAM modulation with CC code rate 2/3 using WiMAX protocol with the Spatial Multiplexing technique of MIMO in the presence of Nakagami channel.

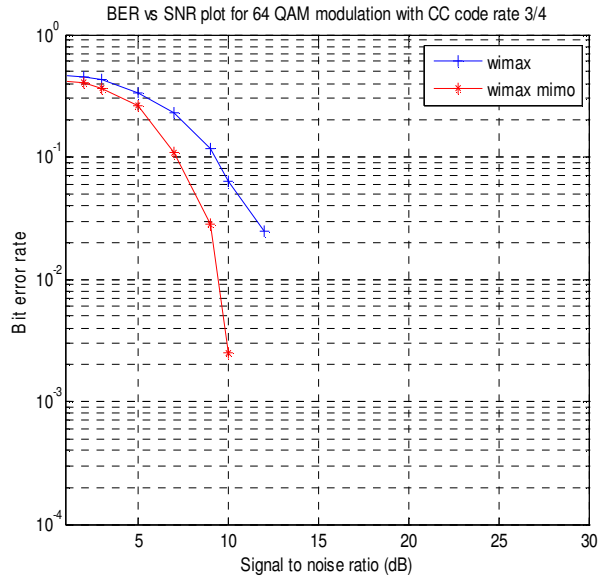

(g) 64 QAM with CC code rate 3/4

This graph shows an SNR improvement of 2dB in WiMAX-MIMO system in the presence of Nakagami channel using 64QAM modulation with CC code rate of 3/4.

Figure 9: BER vs SNR plots for Nakagami channel

- a) BPSK code rate 1/2 b) QPSK code rate 1/2 c) QPSK code rate 3/4 d) 16 QAM code rate 1/2
- e) 16 QAM code rate 3/4 (f) 64 QAM code rate 2/3 (g) 64 QAM code rate 3/4

The performance of WiMAX-MIMO system with different modulations and different CC code rates have been presented in the form of BER vs SNR plots over Nakagami channel in Figure 9 (a)–(g). Each graph shows an improvement in the SNR value using spatial Multiplexing technique of MIMO system which is given in the following table.

TABLE 2: SNR improvement in Nakagami channel by using Spatial Multiplexing in WiMAX

MODULATION	SNR Improvement using Nakagami channel (dB)
BPSK code rate 1/2	1dB
QPSK code rate 1/2	3dB
QPSK code rate 3/4	2dB
16 QAM code rate 1/2	3dB
16 QAM code rate 3/4	3dB
64QAM code rate 2/3	3dB
64QAM code rate 3/4	2dB

8. CONCLUSION

In this paper analysis of MIMO spatial multiplexing technique in 802.16e PHY layer has been simulated and the improvement is shown in the form of SNR value for each of the fading channels that can be seen in BER vs SNR plots. Rician and Nakagami fading channels have been taken into account for the analysis of WiMAX-MIMO system. Simulations show that there is improvement in the SNR value when compared to simple WiMAX standard. Results show that BER reduces to zero value for a lower SNR value when we employ MIMO system in WiMAX for different modulation schemes and different CC code rates. This shows that employing MIMO systems in WiMAX protocol improves the overall performance of the WiMAX system.

REFERENCES

- [1] IEEE 802.16 WG. IEEE Standard for Local and Metropolitan Area Networks - Part 16: Air Interface for Broadband Wireless Access Systems, IEEE 802.16, 2009.
- [2] IEEE 802.11 WG. Draft Standard for Local and Metropolitan Area Networks - Part 11: Wireless LAN Medium Access Control (MAC) and Physical Layer (PHY) specifications. Amendment 5: Enhancements for Higher Throughput. IEEE Draft, 2009.
- [3] Y. Mlayeh, F. Rouissi, F. Tlili & A. Ghazel, "Improvement Technique of Channel Estimation in OFDM-MIMO Systems", 16th IEEE International Conference on Electronics, Circuits & Systems, pp 467-470, 2009.
- [4] Z. Abichar, Y. Peng & J. M. Chang, "WiMAX: The Emerging of Wireless Broadband", IEEE Computer Society, IT Pro, pp 44-48, 2006.
- [5] "IEEE 802.16a Standard and WiMAX Igniting Broadband Wireless Access", White Paper, 2006.
- [6] Part 11: Wireless LAN Medium Access Control (MAC) and Physical Layer (PHY) Specifications: High-Speed Physical Layer in the 5 GHz Band, IEEE Standard 802.11a, 1999.
- [7] M. N. Khan & S. Ghauri, "The WiMAX 802.16e Physical Layer Model", IET International Conference on Wireless, Mobile & Multimedia Networks, pp 117-120, 2008.
- [8] O. Arafat & K. Dimyati, "Performance Parameter of Mobile WiMAX: A Study on the Physical Layer of Mobile WiMAX under Different Communication Channels & Modulation Technique", Second International Conference on Computer Engineering and Applications, pp 533-537, 2010.
- [9] Y. Mlayeh, F. Rouissi, F. Tlili & A. Ghazel, "Improvement Technique of Channel Estimation in OFDM-MIMO Systems", 16th IEEE International Conference on Electronics, Circuits & Systems, pp 467-470, 2009.
- [10] Z. Abichar, Y. Peng & J. M. Chang, "WiMAX: The Emerging of Wireless Broadband", IEEE Computer Society, IT Pro, pp 44-48, 2006.
- [11] C. Mehlhruer, S. Caban & M. Rupp, "Experimental evaluation of adaptive modulation and coding in MIMO WiMAX with limited feedback", EURASIP Journal on Advances in Signal Processing, pp 1-13, 2008.
- [12] H. B. Voelcker, "Phase-shift keying in fading channels", In IEEE Proceeding on Electronics and Communication Engineering, pp 31-38, 2006.

- [13] L. Zheng & D. Tse, "Diversity and Multiplexing: A Fundamental Tradeoff in Multiple Antenna," IEEE Transaction on Information Theory, pp. 1073 – 1096, 2003.
- [14] J. Benes & J. Prokopec, "Efficiency of Encoding Schemes in Mobile WiMAX", 21st International Conference on Radioelectronika, Vol. 13, 2011.
- [15] S. M. Alamouti, "A Simple Transmit Diversity Technique for Wireless Communication", IEEE Journal on Select Areas in Communications, pp 1451-1458, 1998.
- [16] H. Jafarkhani, "A Quasi-Orthogonal Space–Time Block Code", IEEE Transaction on Communications, pp 42-45, 2001.
- [17] N. Sharma & C. B. Papadias, "Improved Quasi-Orthogonal Codes through Constellation Rotation", IEEE Transaction on Communications, pp 332-335, 2003.
- [18] B. Badic, P. Fuxjaeger & H. Weinrichter, "Performance of quasi-orthogonal space-time code with antenna selection", Electronics Letters , pp 1282-1284, 2004.
- [19] S. S. H. Badaki, S. Talebi & M. Shahabinejad "A Full-Rate Full-Diversity 2x2 Space-Time Block Code with Linear Complexity for the Maximum Likelihood Receiver", IEEE Communications Letters, No. 8, 2011.
- [20] M. M. Jabbari & H. Nooralizadeh, "Advantages of MIMO Channel Estimation on Rician Flat Fading Environments", International Conference on Electronic Devices, Systems and Applications (ICEDSA), pp 11-16, 2011.